

# STONE<sup>wiz</sup><sup>®</sup>

Architectural Cladding. Elegant Living.



**MANUFACTURED ARCHITECTURAL STONE CLADDINGS**





## BRINGING YOU CLOSER TO NATURE

We at **StoneWiz Manufacture Architectural Stone Wall Veneer** which harnesses the elegance and beauty of nature. Our proprietary blend of natural ingredients and the craftsmanship of our artisans has enabled us to create a product which captures the inherent beauty of natural stone without the negative environment impact of mining for natural stone. Our designs have been carefully selected from stones available from all across the world. Our artisans work diligently by hand to add life to the designs and manufacture a product which reflects the awe inspiring beauty of nature. When you look closely at our stone veneers you will notice an unmatched detailing of textures and variation of colours.



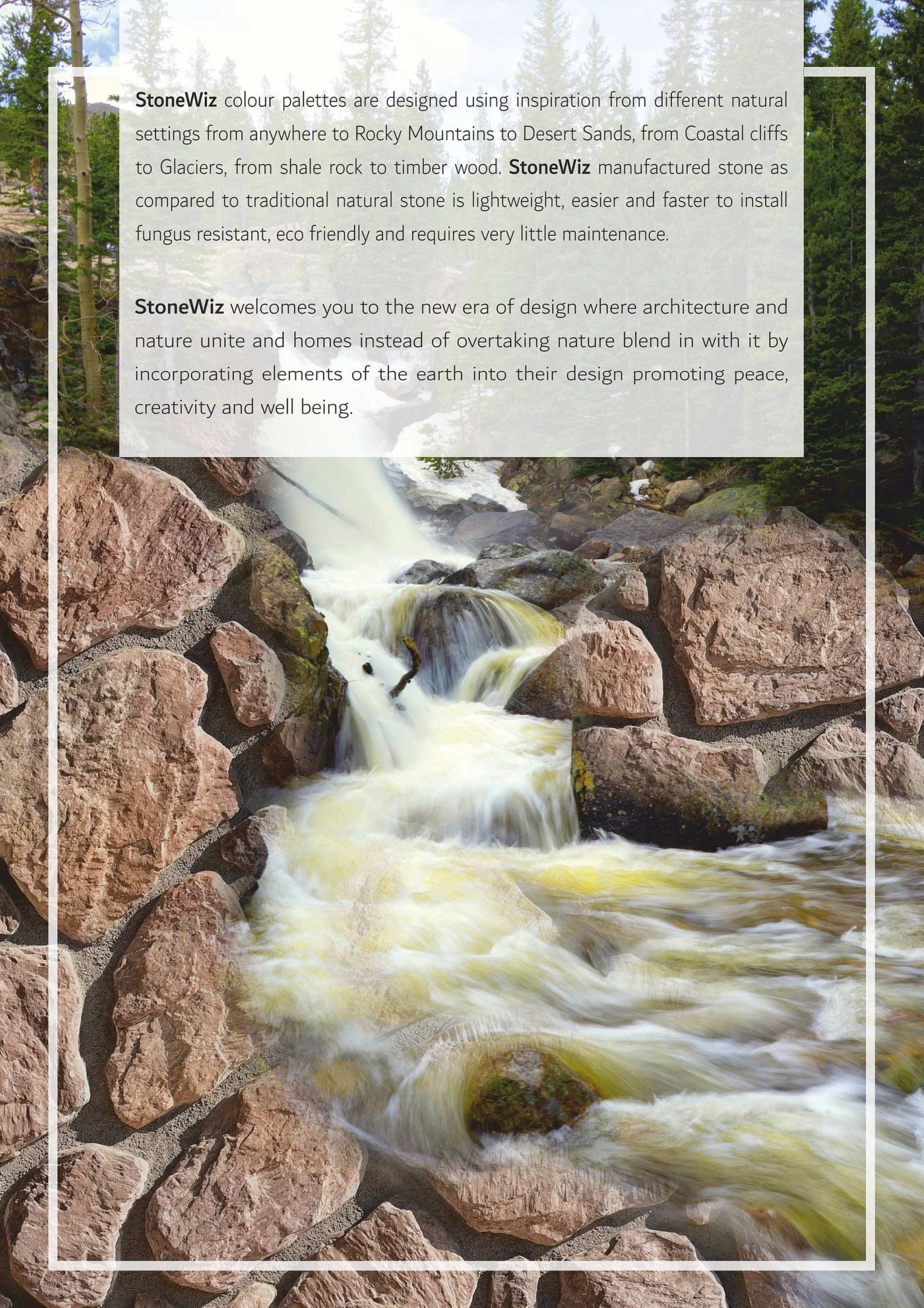

**StoneWiz** colour palettes are designed using inspiration from different natural settings from anywhere to Rocky Mountains to Desert Sands, from Coastal cliffs to Glaciers, from shale rock to timber wood. **StoneWiz** manufactured stone as compared to traditional natural stone is lightweight, easier and faster to install fungus resistant, eco friendly and requires very little maintenance.

**StoneWiz** welcomes you to the new era of design where architecture and nature unite and homes instead of overtaking nature blend in with it by incorporating elements of the earth into their design promoting peace, creativity and well being.



# ROCKY MOUNTAIN LEDGE



MISTY GREY



RUSTIC WHITE



TUNDRA WHITE



ARCTIC WHITE



HIGHLAND CREAM



COASTAL CREAM



BLACK RIVER



BLACK PEARL





ROCKY MOUNTAIN LEDGE-MISTY GREY



MANUFACTURED ARCHITECTURAL STONE CLADDINGS



ROCKY MOUNTAIN LEDGE-MISTY GREY



MANUFACTURED ARCHITECTURAL STONE CLADDINGS



ROCKY MOUNTAIN LEDGE-RUSTIC WHITE



MANUFACTURED ARCHITECTURAL STONE CLADDINGS

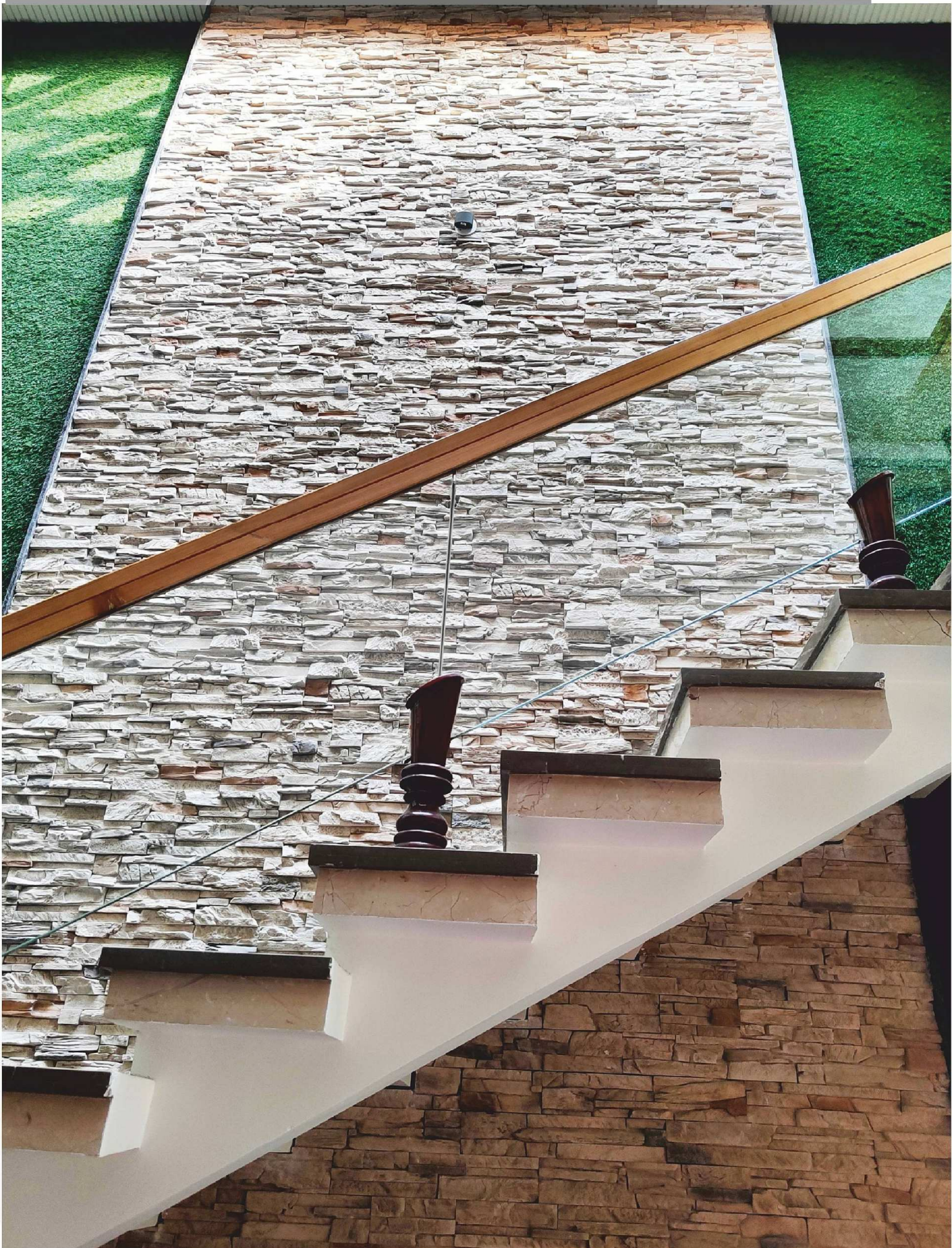

ROCKY MOUNTAIN LEDGE-TUNDRA WHITE



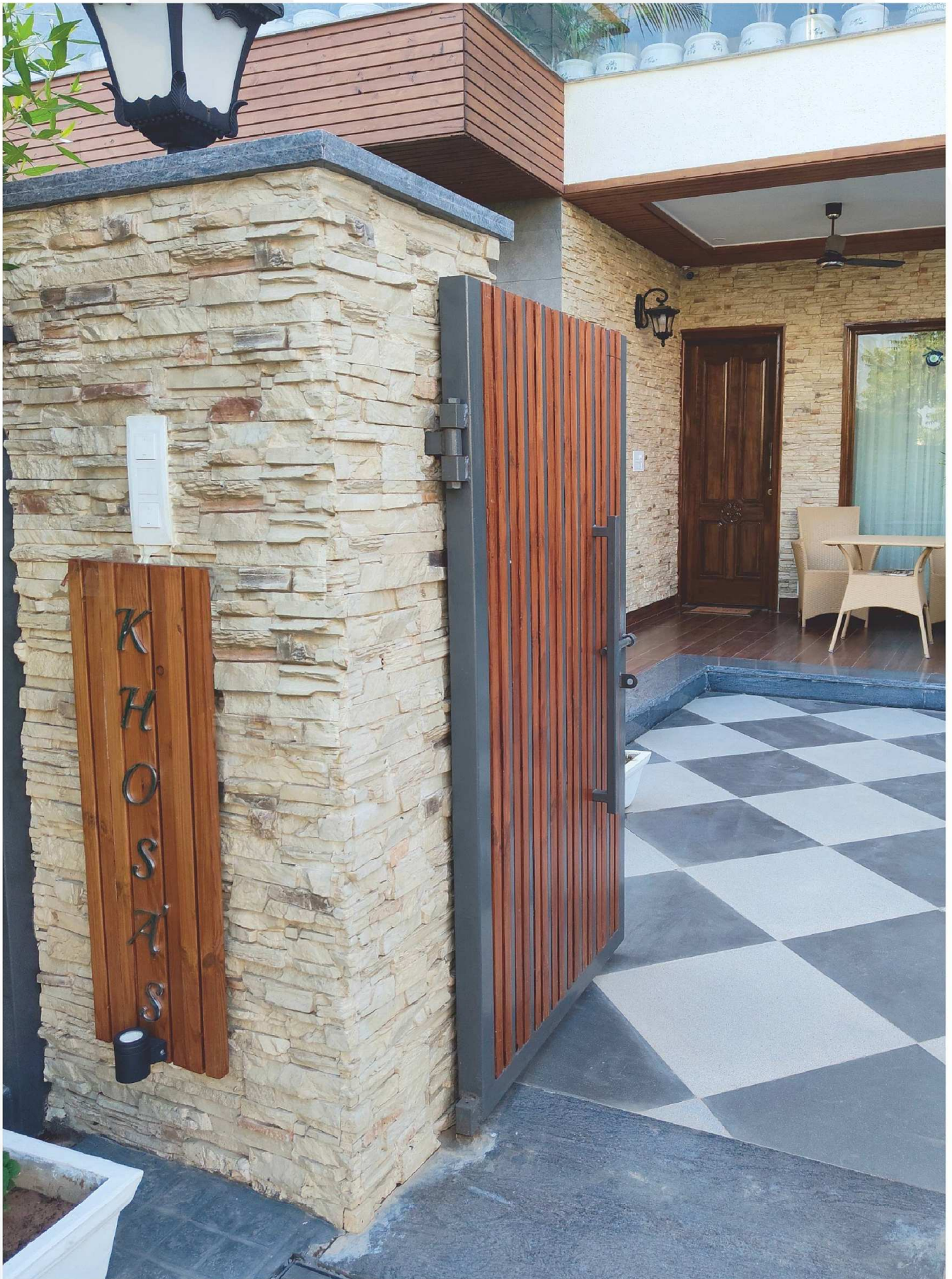

ROCKY MOUNTAIN LEDGE-ARCTIC WHITE





ROCKY MOUNTAIN LEDGE-ARCTIC WHITE





ROCKY MOUNTAIN LEDGE-TUNDRA WHITE



MANUFACTURED ARCHITECTURAL STONE CLADDINGS

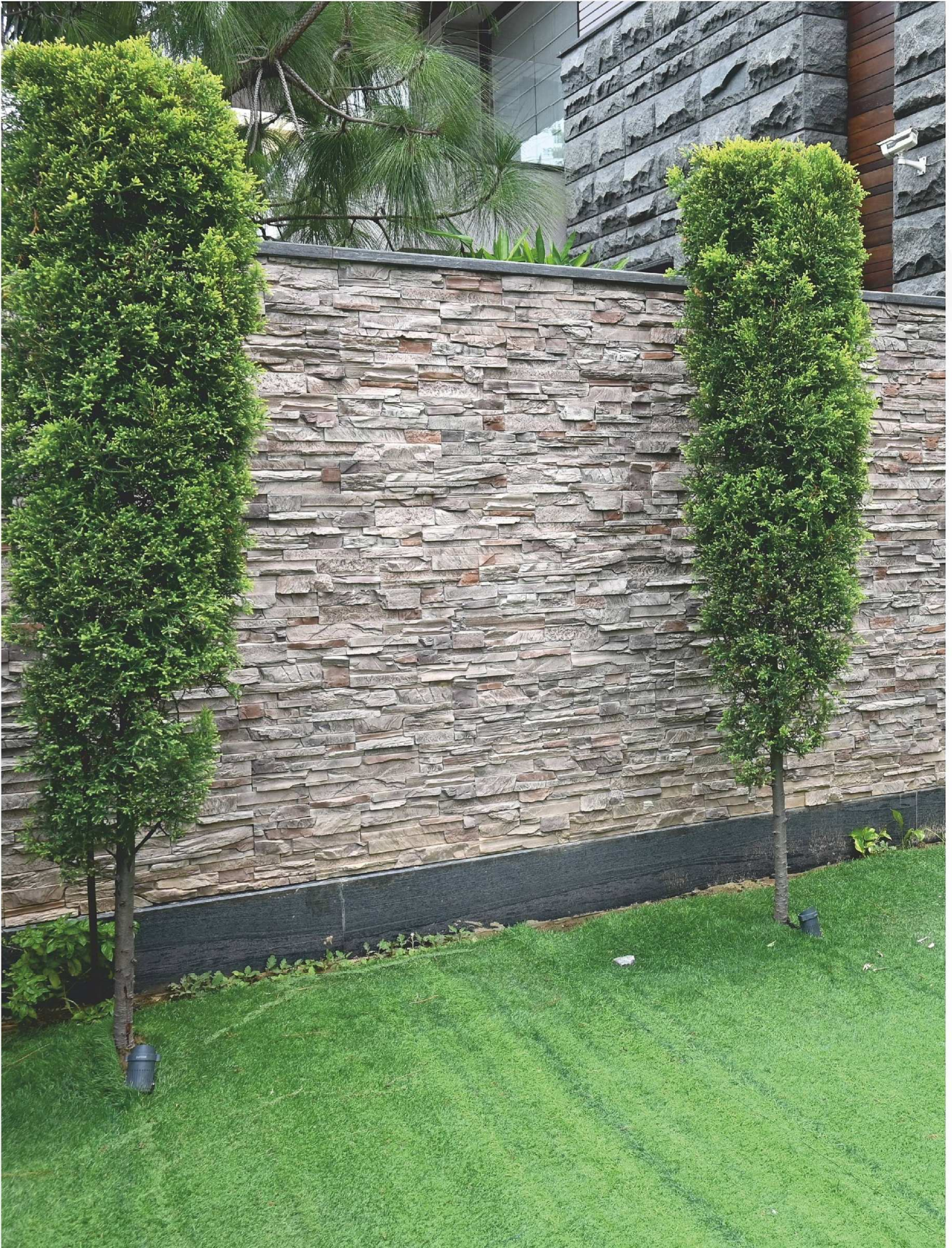

ROCKY MOUNTAIN LEDGE- RUSTIC WHITE





ROCKY MOUNTAIN LEDGE-BLACK RIVER



MANUFACTURED ARCHITECTURAL STONE CLADDINGS



ROCKY MOUNTAIN LEDGE-BLACK PEARL



**MANUFACTURED ARCHITECTURAL STONE CLADDINGS**





**ROCKY MOUNTAIN LEDGE-HIGHLAND CREAM**



**ROCKY MOUNTAIN LEDGE-COASTAL CREAM**

**SPECIFICATION (ROCKY MOUNTAIN LEDGE)**

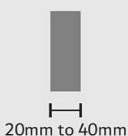
Flat Stone	Corner Stone	Thickness
 <p>Weight of stone: 4 kg per sq. ft (Approx.)</p>	 <p>Area covered per running feet= 1.08 sq. ft.</p>	 <p>20mm to 40mm</p>



MANUFACTURED ARCHITECTURAL STONE CLADDINGS

# ALPINE LEDGE



MISTY GREY



QUARTZ



LUXOR





ALPINE LEDGE-LUXOR



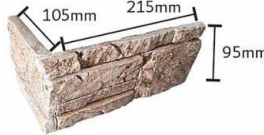

ALPINE LEDGE-MISTY GREY

SPECIFICATION (ALPINE LEDGE)

Flat Stone	Corner Stone	Thickness
 <p>400mm/250mm/150mm</p> <p>Weight of stone: 2.25 kg per sq. ft. (Approx.)</p>	 <p>Area covered per running feet= 1.05 sq. ft.</p>	 <p>15mm to 20mm</p>



# CALIFORNIA LEDGE



CANYON GREY



HIGHLAND CREAM



ARCTIC WHITE

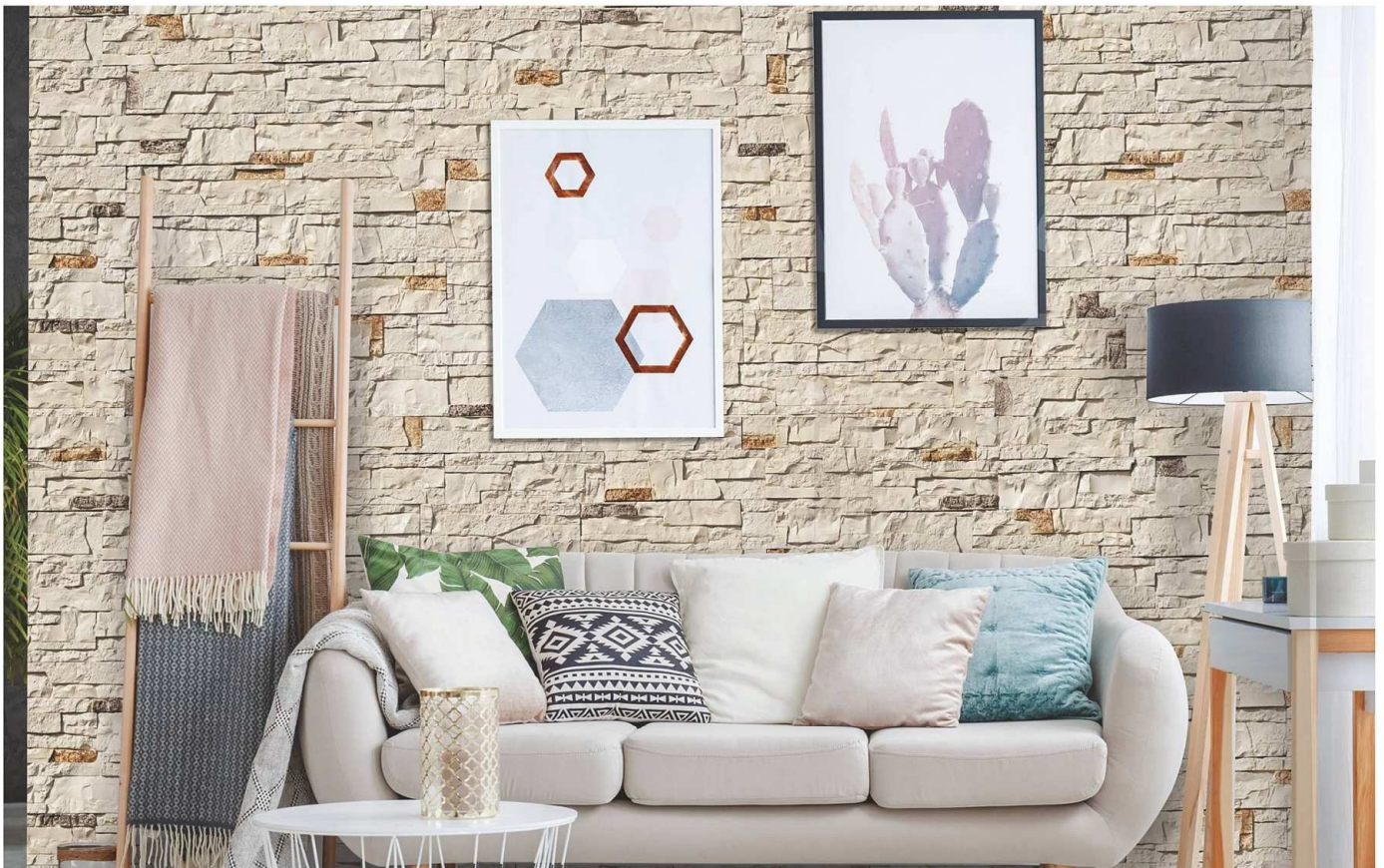

CALIFORNIA LEDGE-ARCTIC WHITE



MANUFACTURED ARCHITECTURAL STONE CLADDINGS



ROCKY MOUNTAIN LEDGE-ARCTIC WHITE

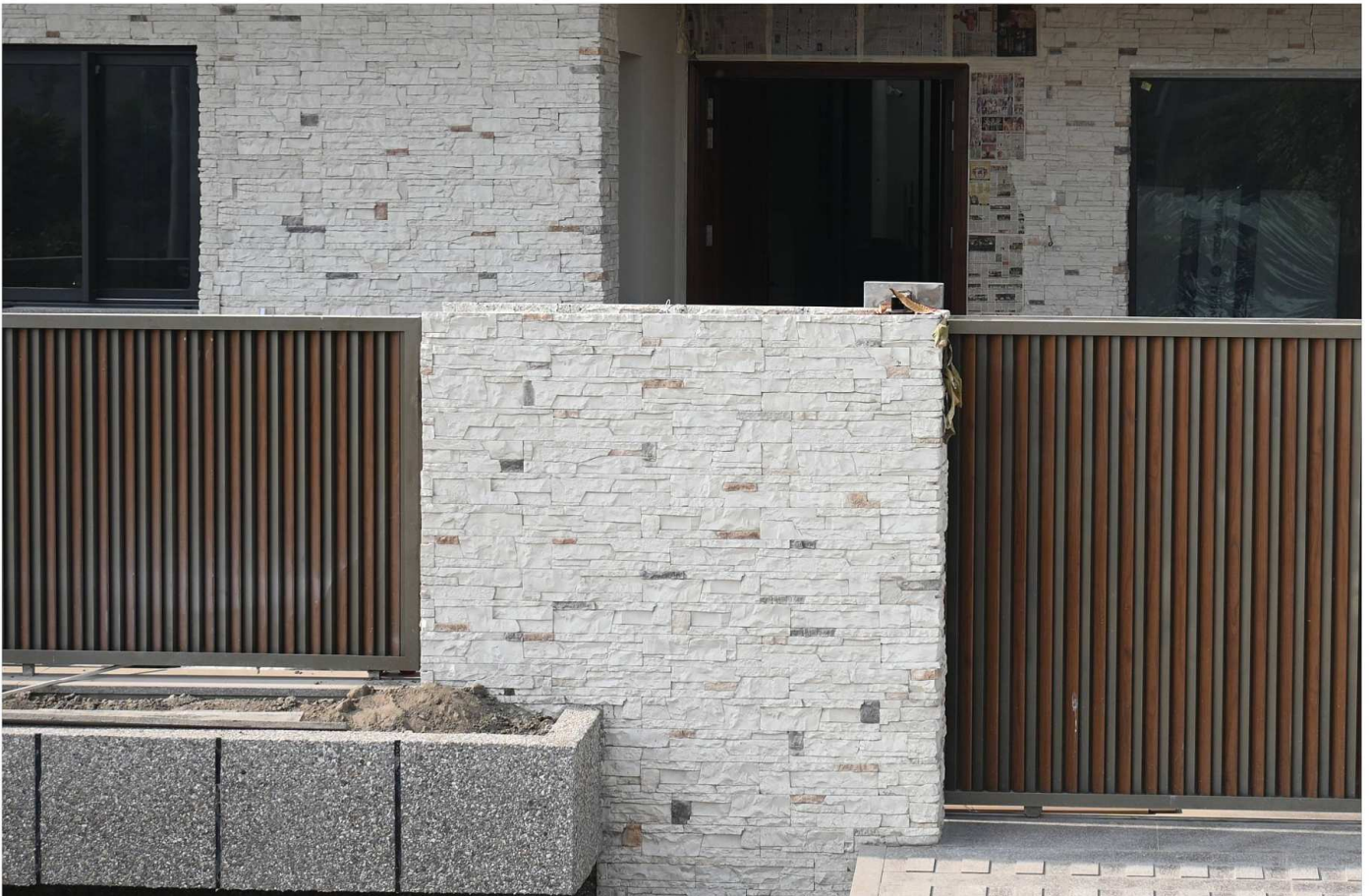





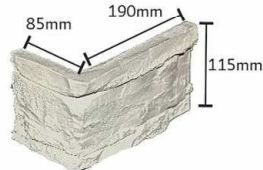

CALIFORNIA LEDGE-HIGHLAND CREAM

SPECIFICATION (CALIFORNIA LEDGE)

Flat Stone	Corner Stone	Thickness
 <p>Weight of stone: 3.2 kg per sq. ft. (Approx.)</p>	 <p>Area covered per running feet= 0.90 sq. ft.</p>	 <p>25mm to 30 mm</p>



# CANYON LEDGE



**SMOKY GREY**



**SOLANO BROWN**

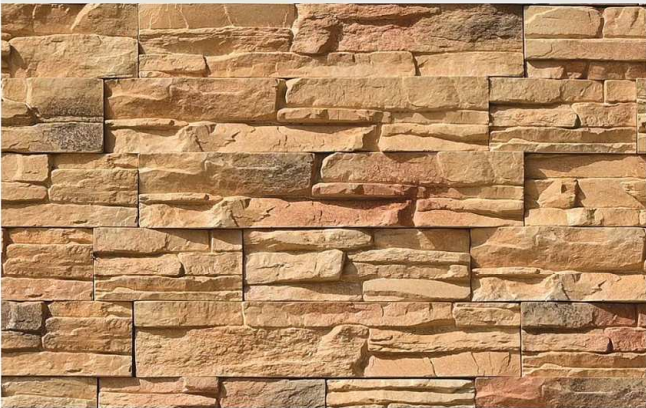

**COASTAL CREAM**





**CANYON GREY**



**RAINFOREST**

## SPECIFICATION (CANYON LEDGE)

Flat Stone	Corner Stone	Thickness
 <p>Weight of stone: 3.5 kg per sq. ft (Approx.)</p>	 <p>Area covered per running feet= 0.69 sq. ft.</p>	 <p>20mm to 35mm</p>





CANYON LEDGE-SMOKY GREY



# SHARP MOUNTAIN LEDGE



BLACK PEARL



SANTORINI

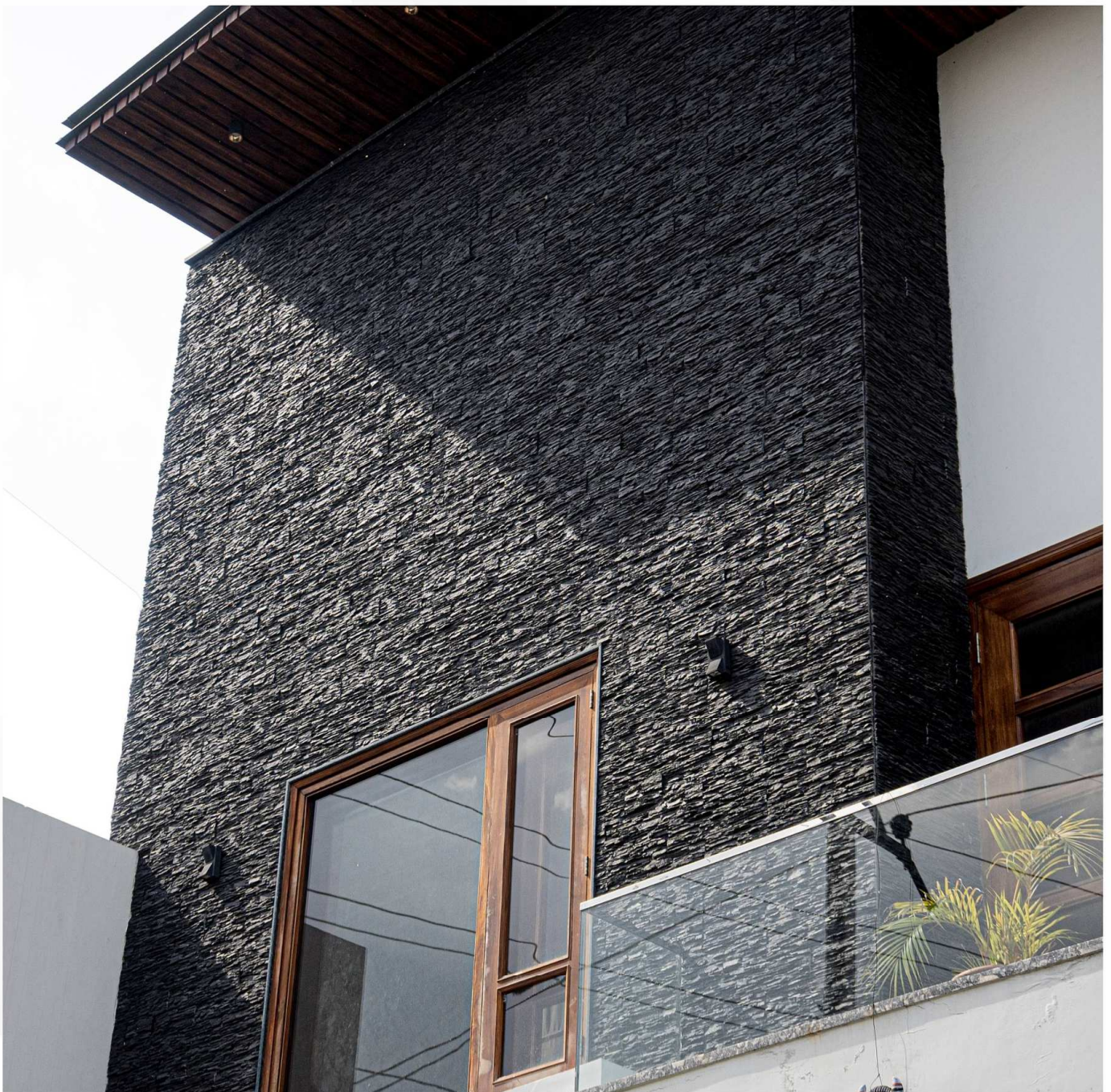

SHARP MOUNTAIN LEDGE-BLACK PEARL





**MANUFACTURED ARCHITECTURAL STONE CLADDINGS**



**SHARP MOUNTAIN LEDGE-SANTORINI**

**SPECIFICATION (SHARP MOUNTAIN LEDGE)**

Flat Stone	Corner Stone	Thickness
 <p>Weight of stone: 3 kg per sq. ft (Approx.)</p>	 <p>Area covered per running feet= 1.31 sq. ft.</p>	 <p>25mm to 30mm</p>

**NEW COLLECTION**

**SHARP CUT LEDGE**





**CHARDONNAY**



**SLATE GREY**

**SPECIFICATION (SHARP CUT LEDGE)**

Flat Stone	Thickness
 <p>Weight of stone: 3 kg per sq. ft (Approx.)</p>	 <p>15mm to 25mm</p>



# EUROPEAN LEDGE



**RAINFOREST**



**MONTAIN BROWN**



**SILVERTON**





**SOLANO BROWN**

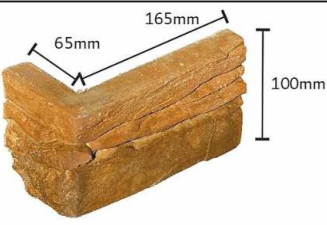

**PEARL**

## SPECIFICATION (EUROPEAN LEDGE)

Flat Stone	Corner Stone	Thickness
 <p>Weight of stone: 4 kg per sq. ft (Approx.)</p>	 <p>Area covered per running feet= 0.75 sq. ft.</p>	 <p>30mm to 35 mm</p>



MANUFACTURED ARCHITECTURAL STONE CLADDINGS



EUROPEAN LEDGE-RAINFOREST

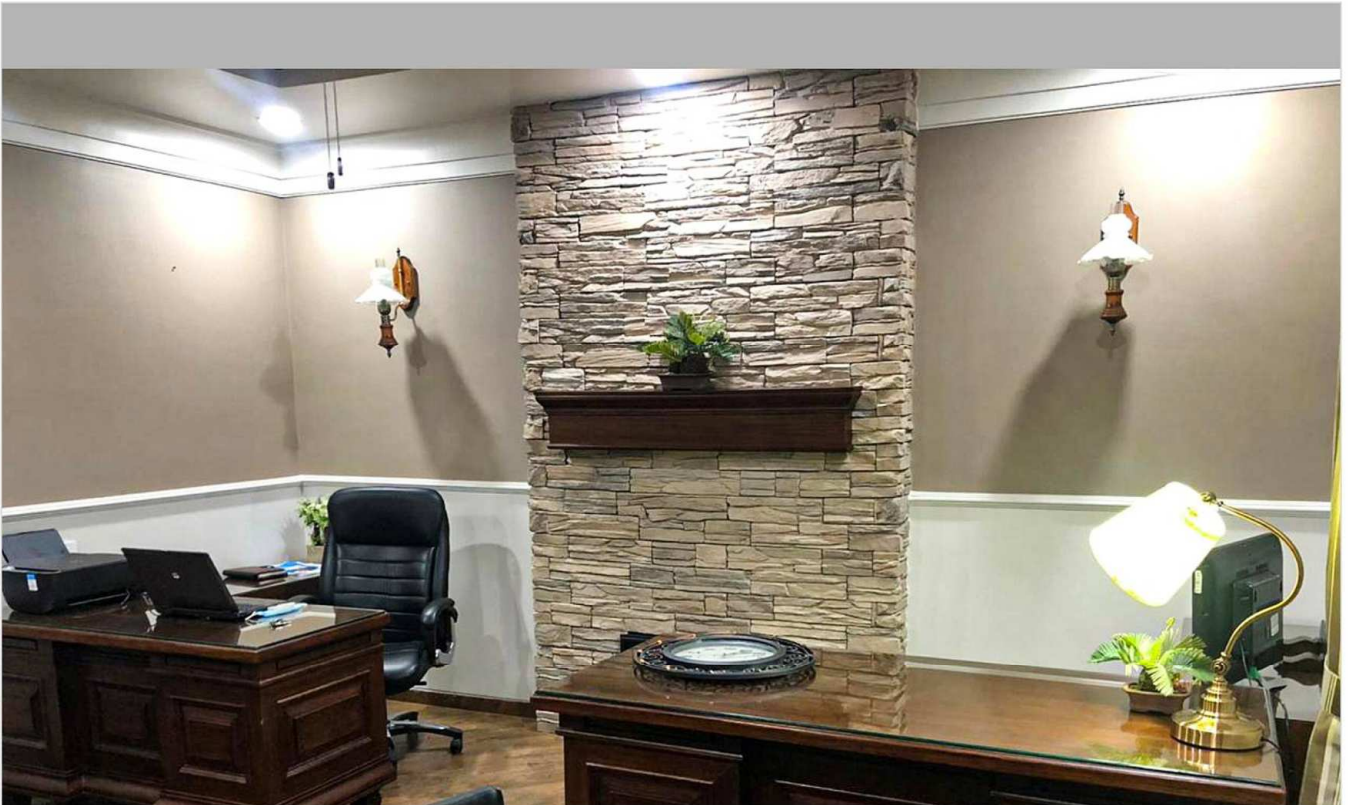

EUROPEAN LEDGE-PEARL



# MONTANA CREEK





COASTAL CREAM

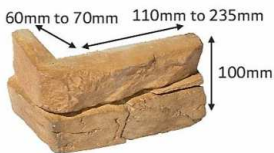

MONTANA CREEK-COASTAL CREAM

## SPECIFICATION (MONTANA CREEK)

Flat Stone	Corner Stone	Thickness
 <p>420mm/280mm/210mm/140mm</p> <p>100mm</p> <p>Weight of stone: 4.5 kg per sq. ft. (Approx.)</p>	 <p>60mm to 70mm 110mm to 235mm</p> <p>100mm</p> <p>Area covered per running feet= 0.80 sq. ft.</p>	 <p>40mm to 45mm</p>



# RUGGED STONE



SILVERTON



LUXOR



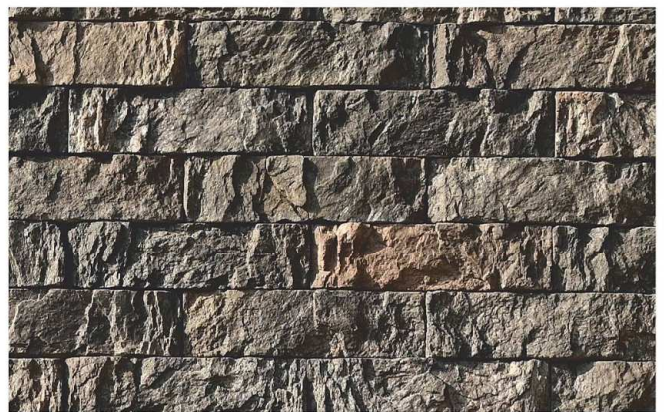

CAIRO



RAINFOREST

## SPECIFICATION (RUGGED STONE)

Flat Stone	Corner Stone	Thickness
 <p>215mm 60mm Weight of stone: 2.7 kg per sq. ft (Approx.)</p>	 <p>105mm 215mm 60mm Area covered per running feet= 1.05 sq. ft.</p>	 <p>14mm to 17mm</p>



MANUFACTURED ARCHITECTURAL STONE CLADDINGS



RUGGED STONE-SILVERTON

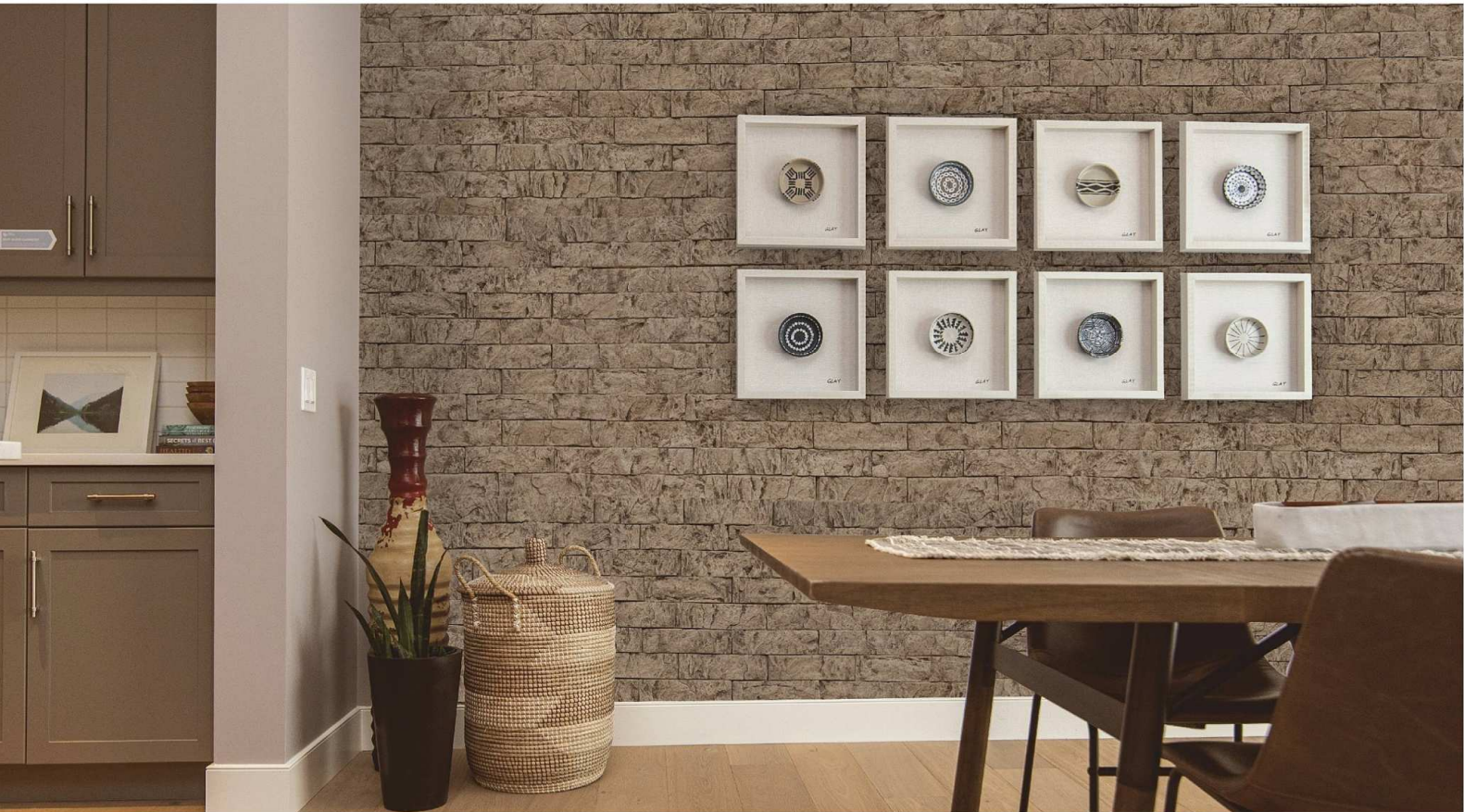



## FIELD STONE



SILVERTON



ASHLAR



COASTAL CREAM

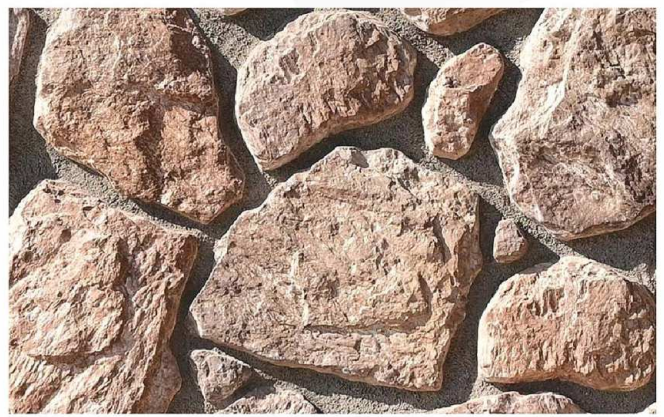

AUTUMN



SANTORINI

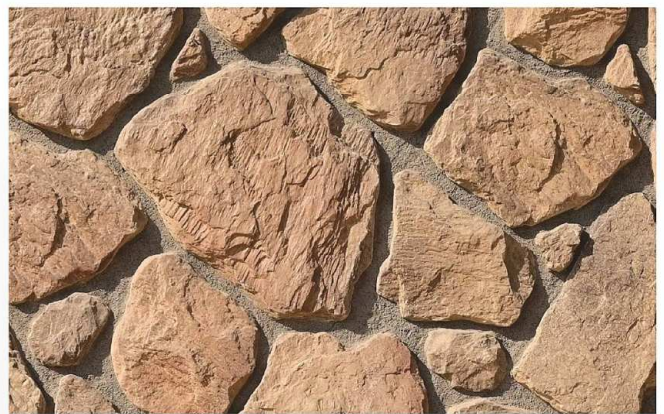

CAIRO



MEDLEY



OYSTER





FIELD STONE-COASTAL CREAM

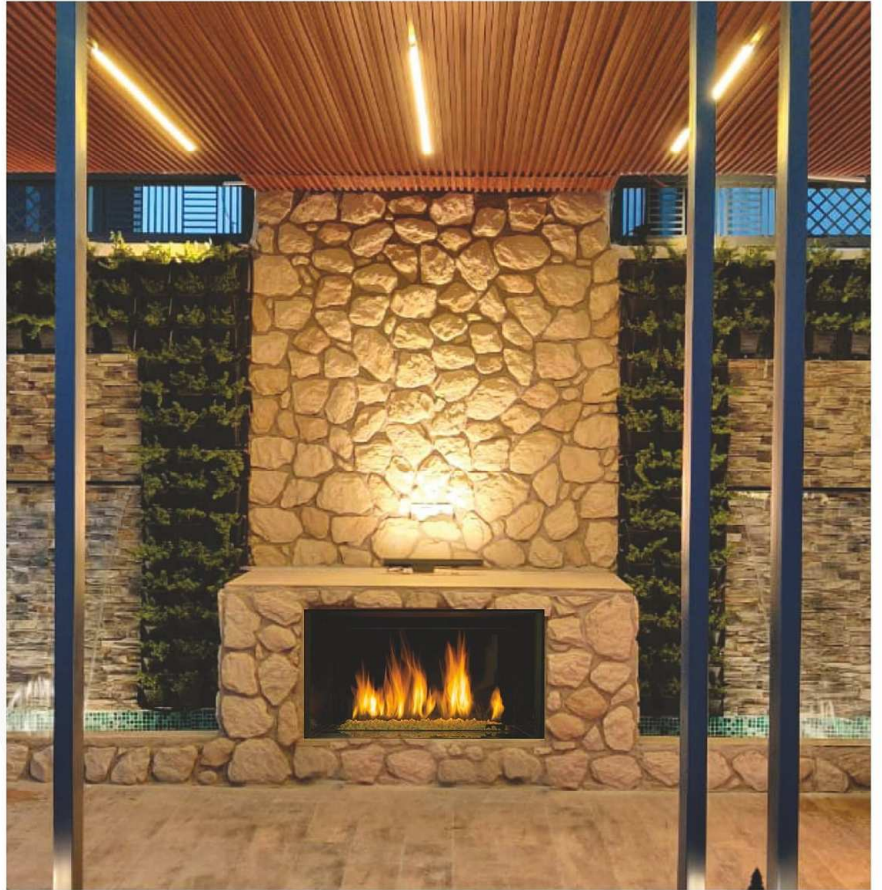





**FIELD STONE-SANTORINI**



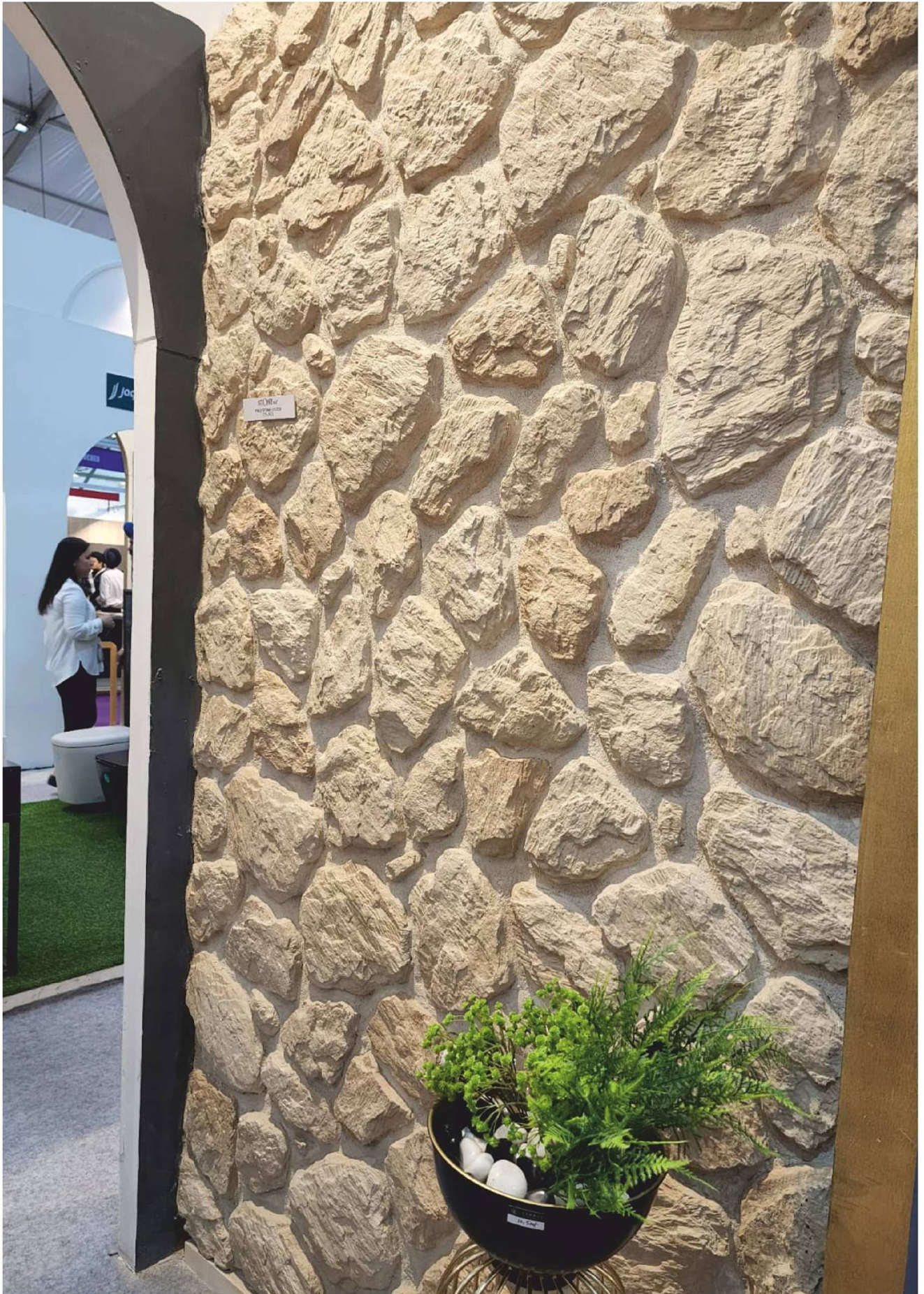

**FIELD STONE-OYSTER**







**FIELD STONE-MEDLEY**

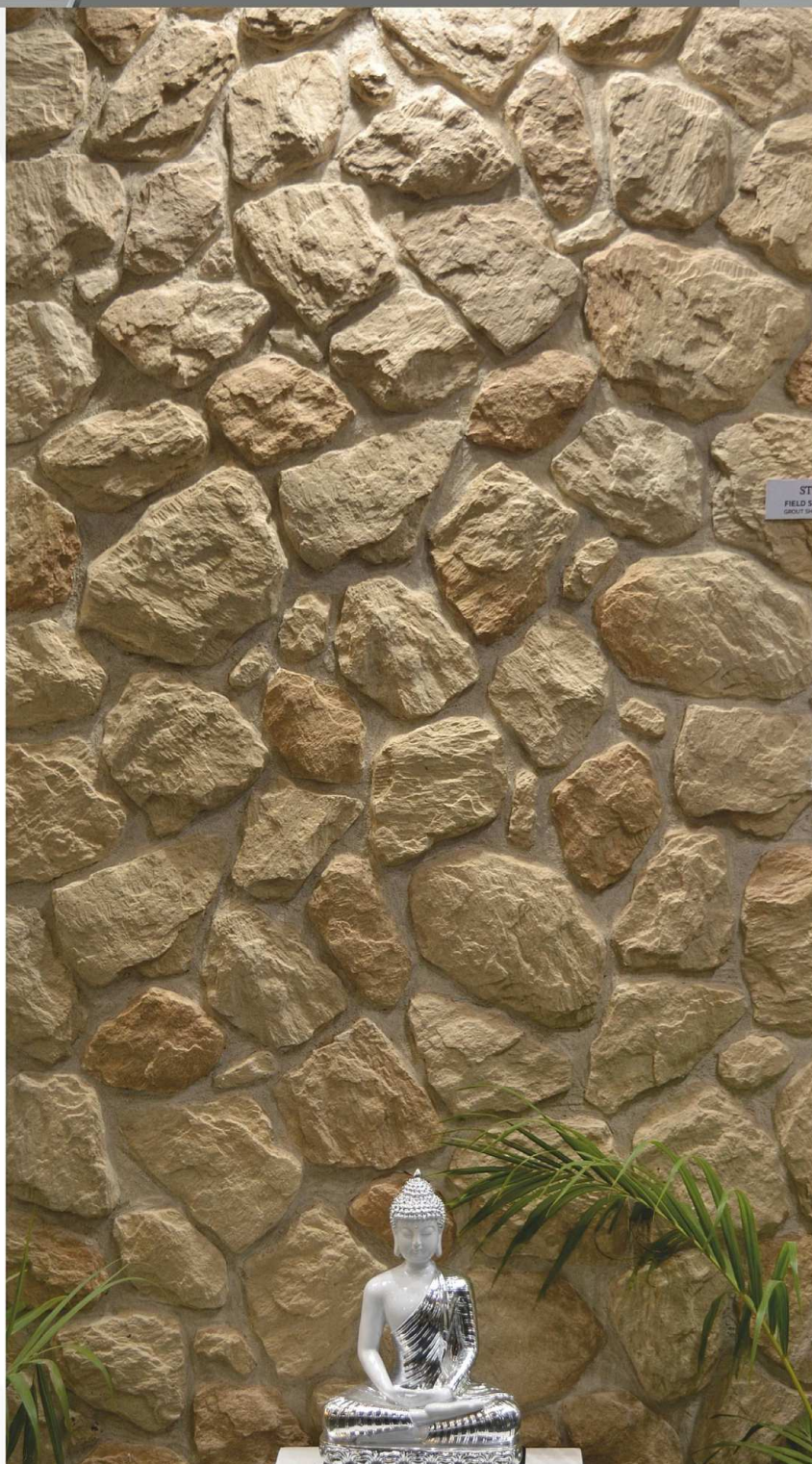

FIELD STONE-COASTAL CREAM

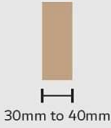

SPECIFICATION (FIELD STONE)

Flat Stone	Thickness
	



# FRENCH VILLA



CAIRO



BLACK FOREST



PEARL



HIGHLAND CREAM



ASHLAR



SILVERTON



RAINFOREST

VILLA





FRENCH VILLA-AMAZONIA



MANUFACTURED ARCHITECTURAL STONE CLADDINGS

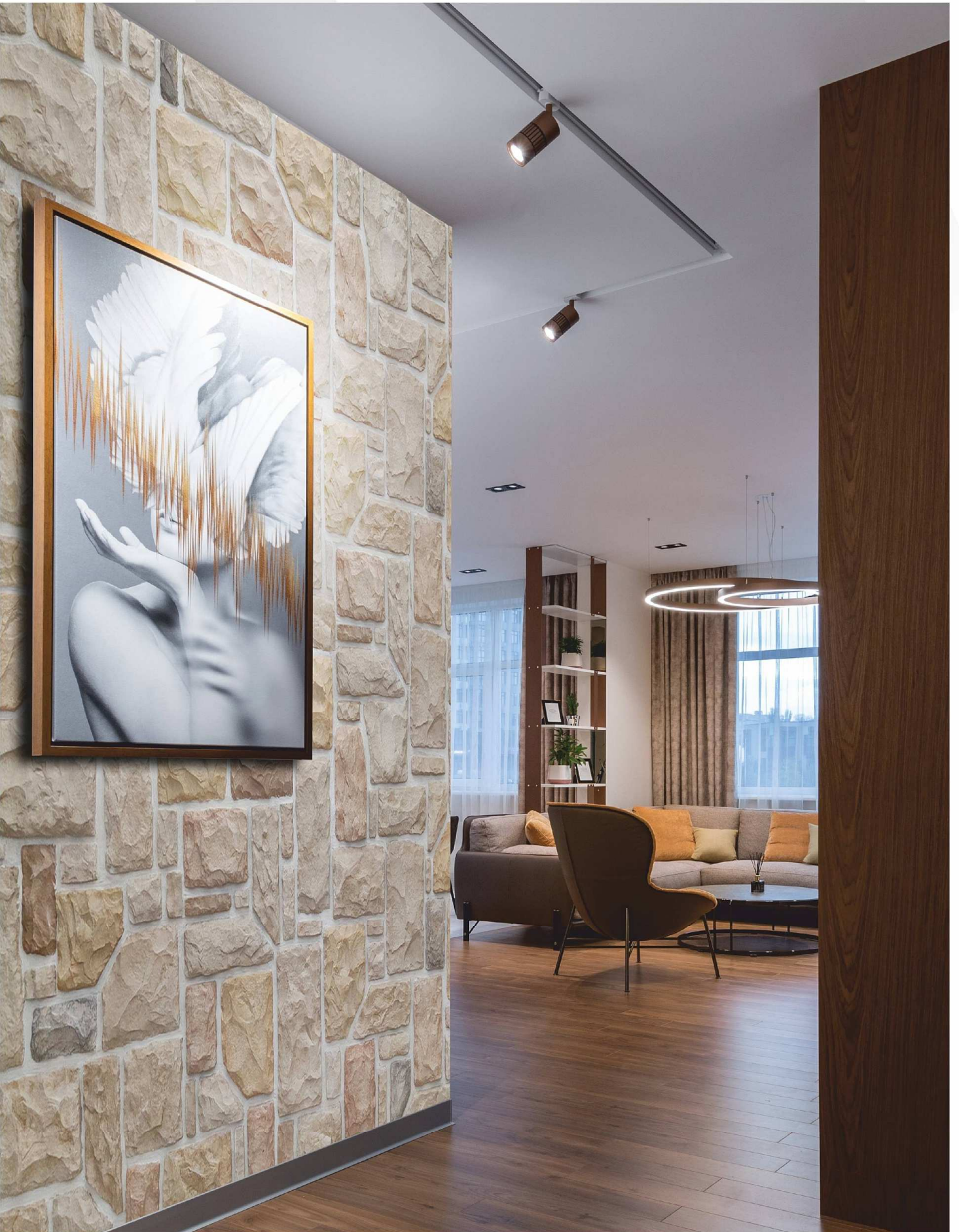



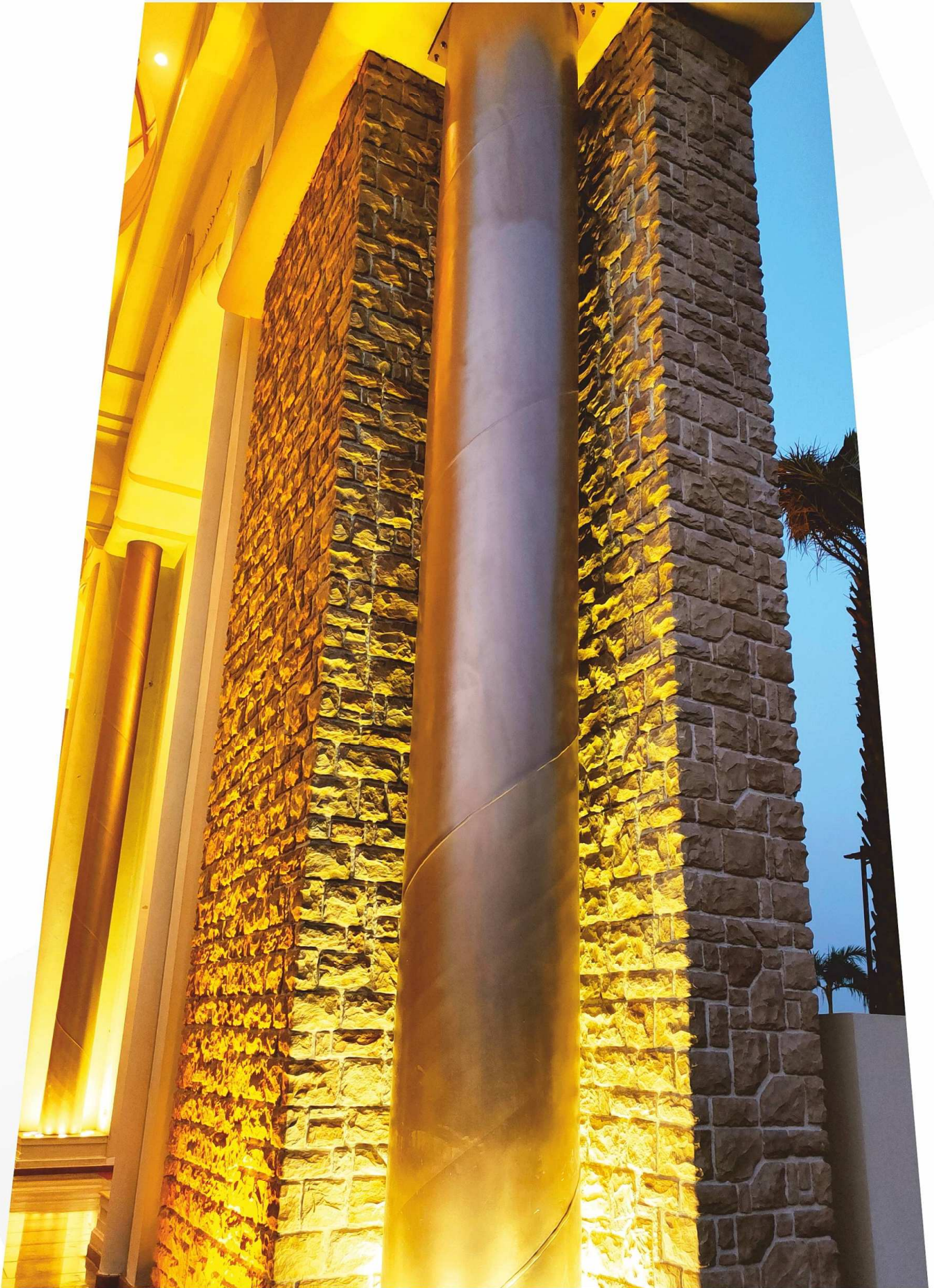

FRENCH VILLA-PEARL





FRENCH VILLA-PEARL



MANUFACTURED ARCHITECTURAL STONE CLADDINGS



FRENCH VILLA-PEARL





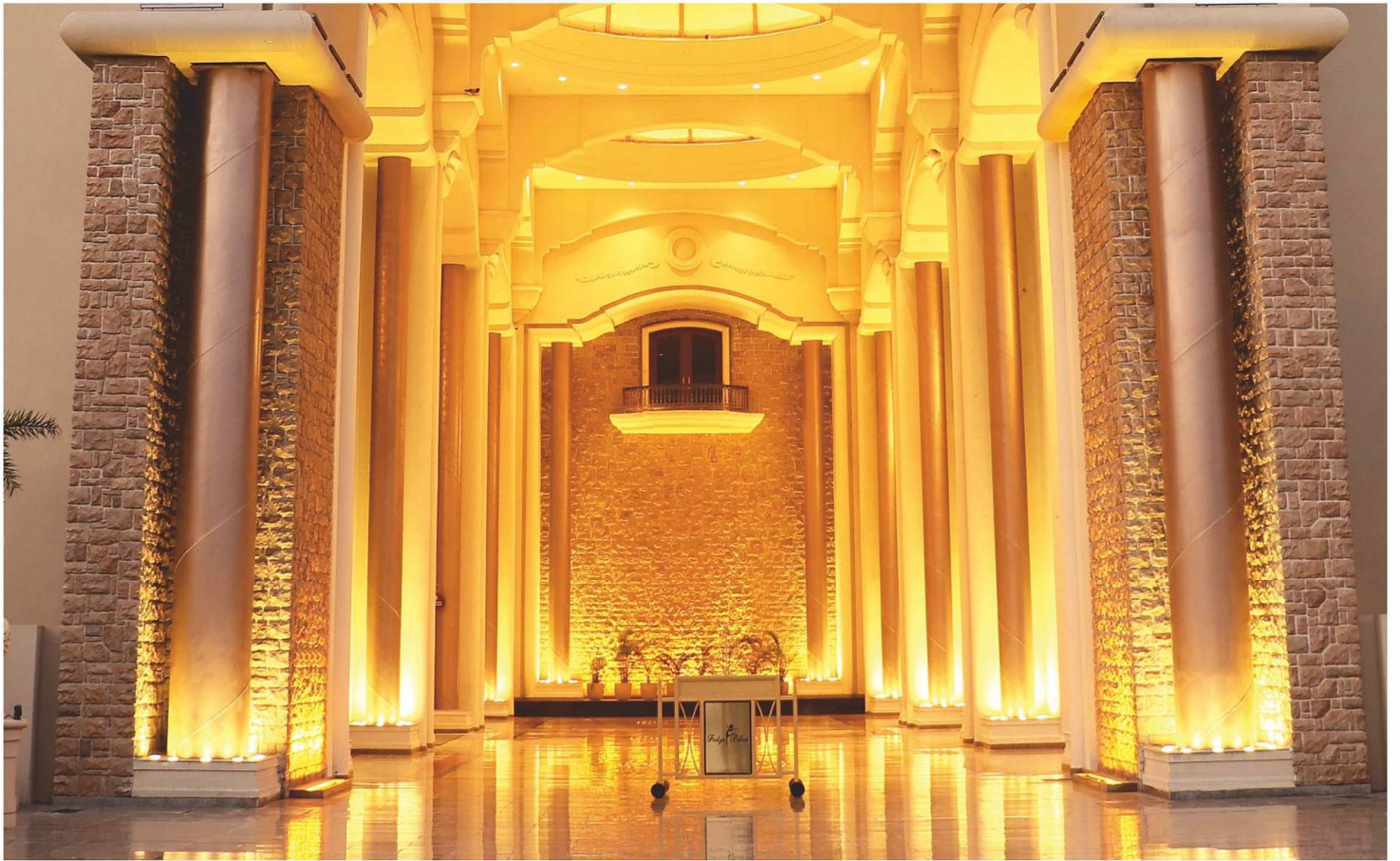

**FRENCH VILLA-PEARL**



MANUFACTURED ARCHITECTURAL STONE CLADDINGS



FRENCH VILLA-PEARL





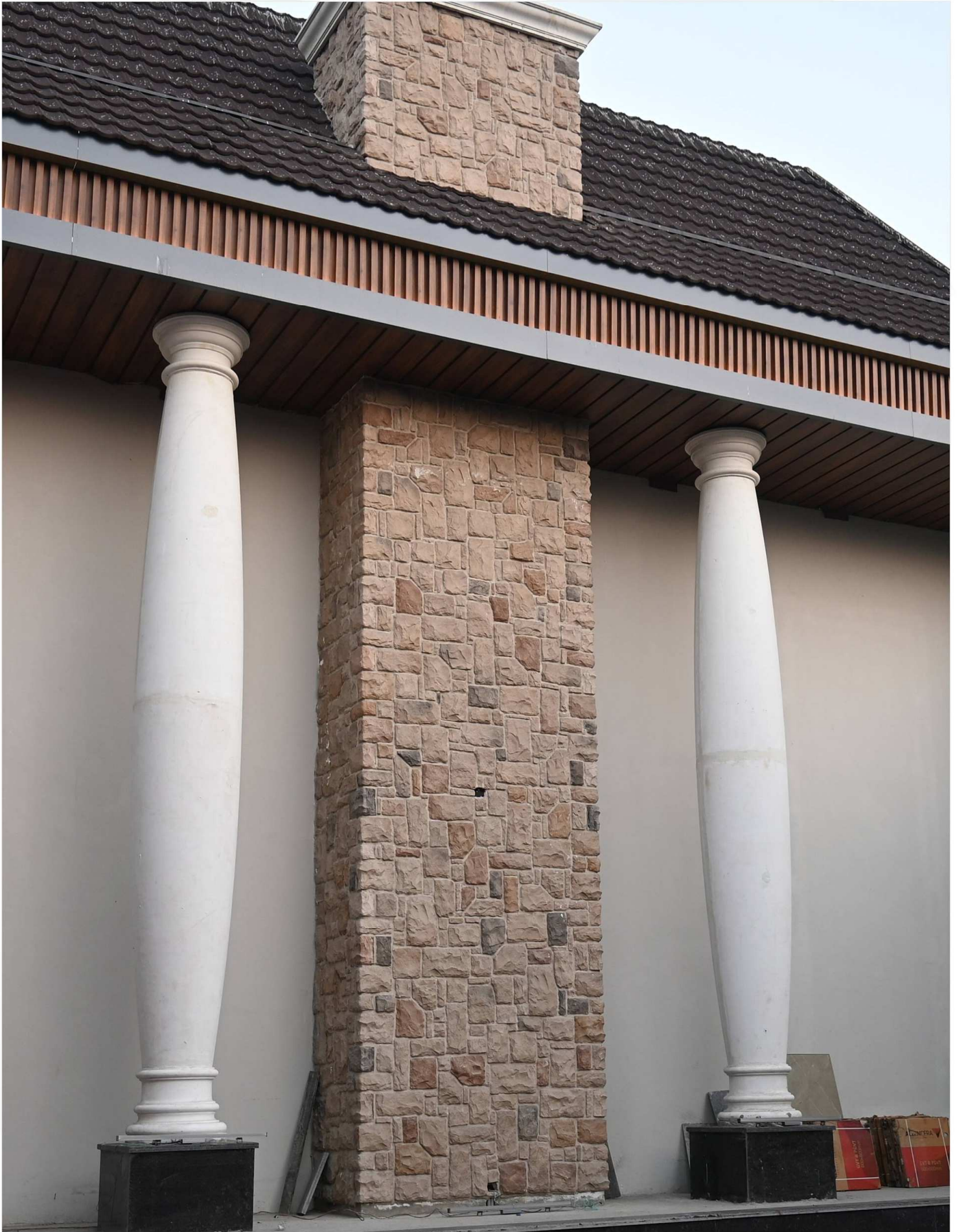

FRENCH VILLA-PEARL



MANUFACTURED ARCHITECTURAL STONE CLADDINGS

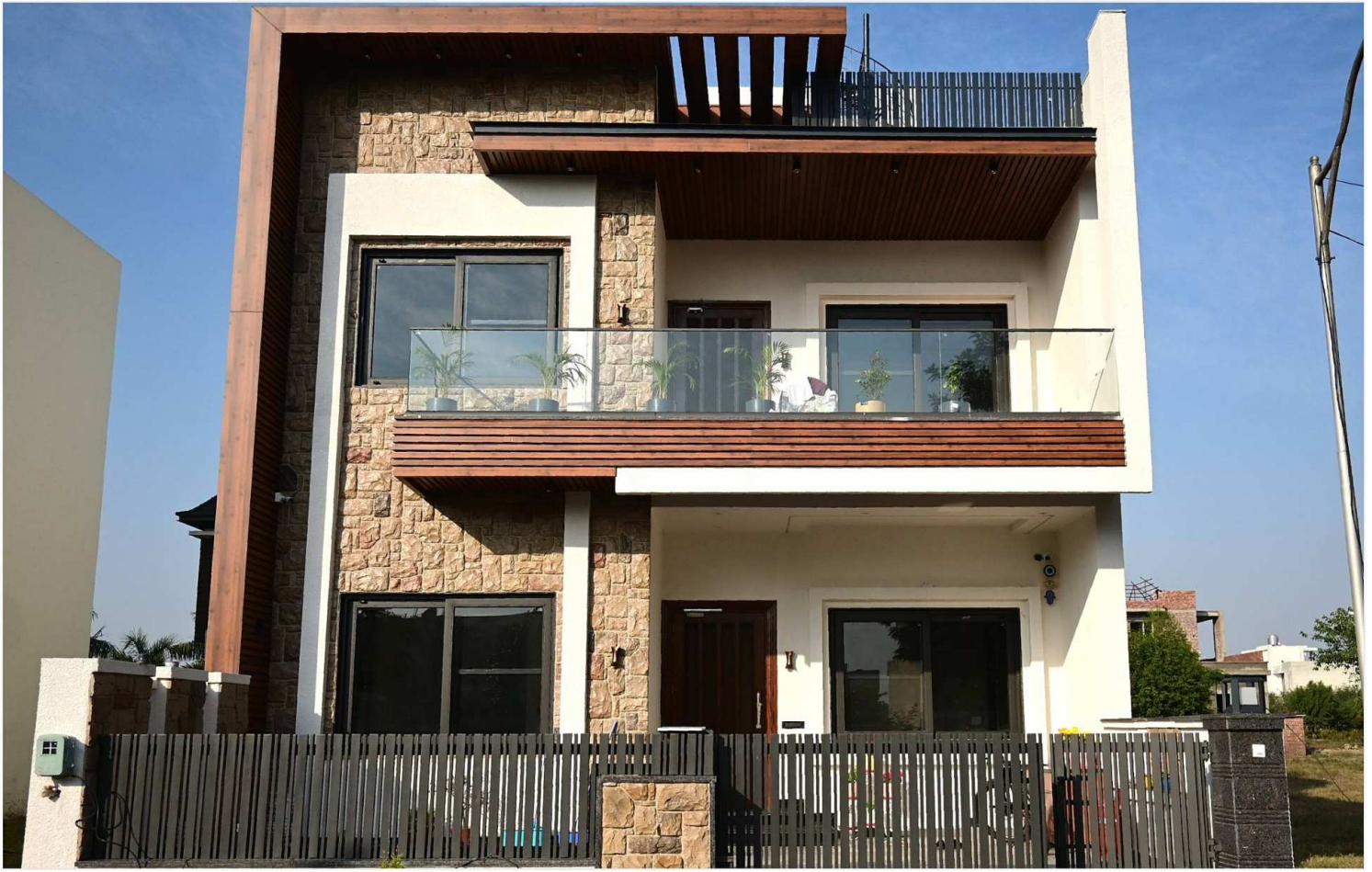

FRENCH VILLA-PEARL

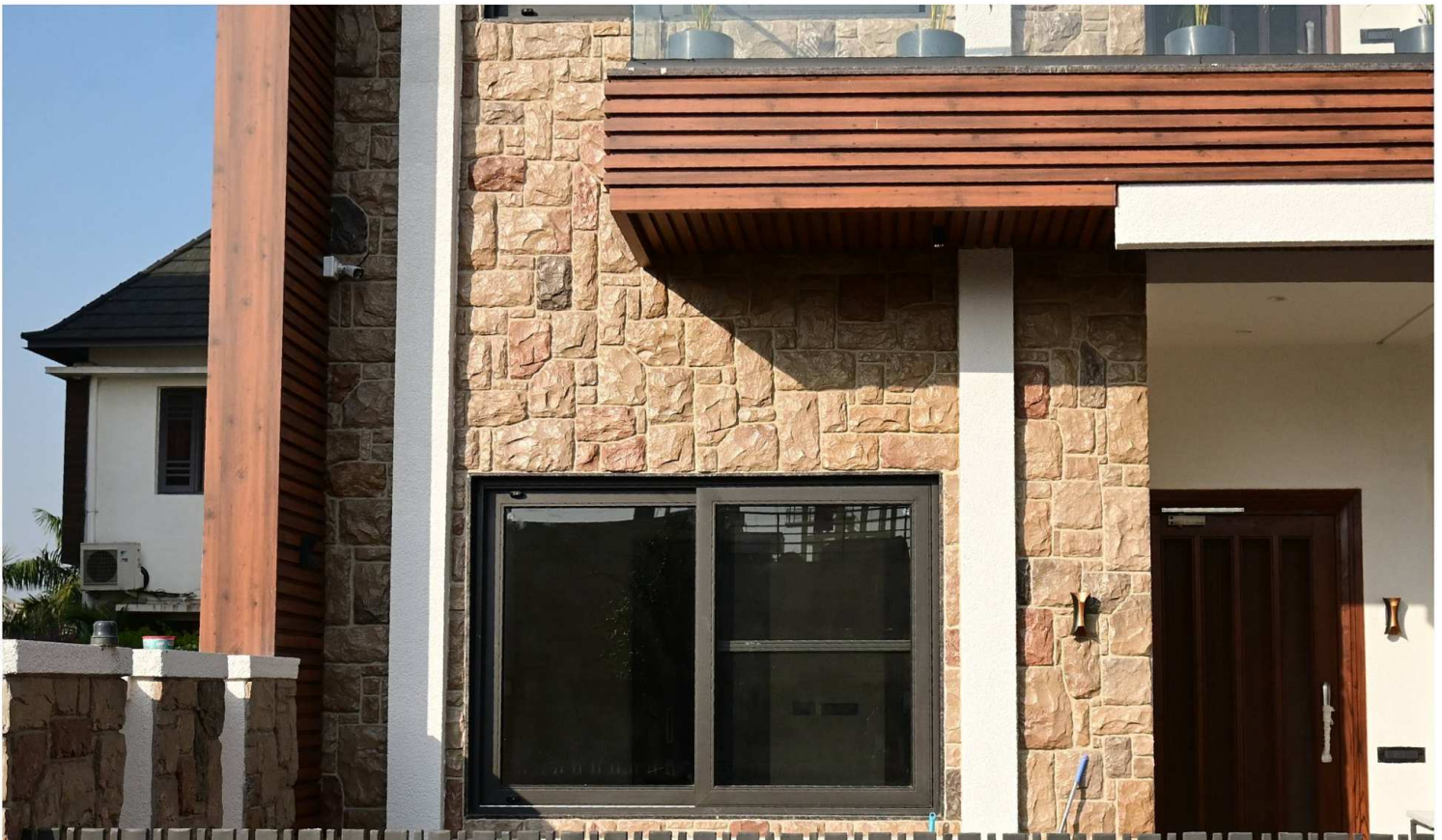





MANUFACTURED ARCHITECTURAL STONE CLADDINGS



FRENCH VILLA-ASHLAR

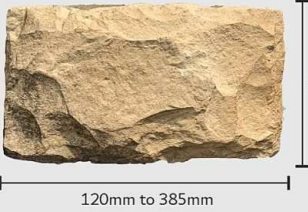
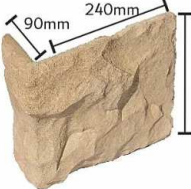

**SPECIFICATION (FRENCH VILLA)**

Flat Stone	Corner Stone	Thickness
 <p>120mm to 385mm</p> <p>35mm to 250mm</p> <p>Weight of stone: 3.5 kg per sq. ft (Approx.)</p>	 <p>90mm 240mm</p> <p>115mm/190mm/205mm</p> <p>Area covered per running feet= 1.08 sq. ft.</p>	 <p>30mm to 40mm</p>



**FRENCH VILLA-PEARL**



# GRAND CANYON



PEARL



SOLANO BROWN



BLACK FOREST



ASHLAR



HIGHLAND CREAM



SANTORINI



QUARTZITE



CANYON RED



MANUFACTURED ARCHITECTURAL STONE CLADDINGS



GRAND CANYON-HIGHLAND CREAM



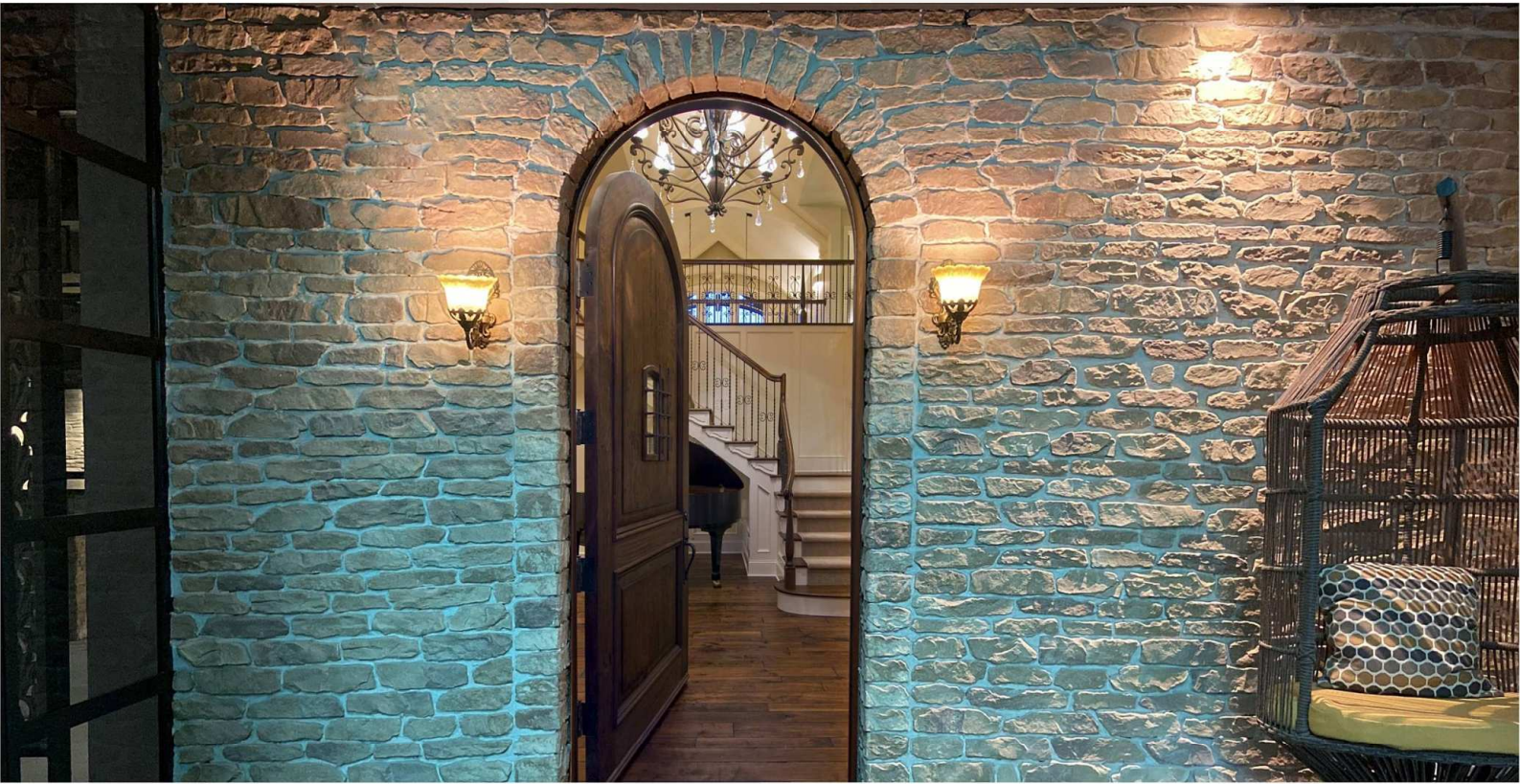

GRAND CANYON-HIGHLAND CREAM



GRAND CANYON-PEARL





GRAND CANYON-SOLANO BROWN



MANUFACTURED ARCHITECTURAL STONE CLADDINGS

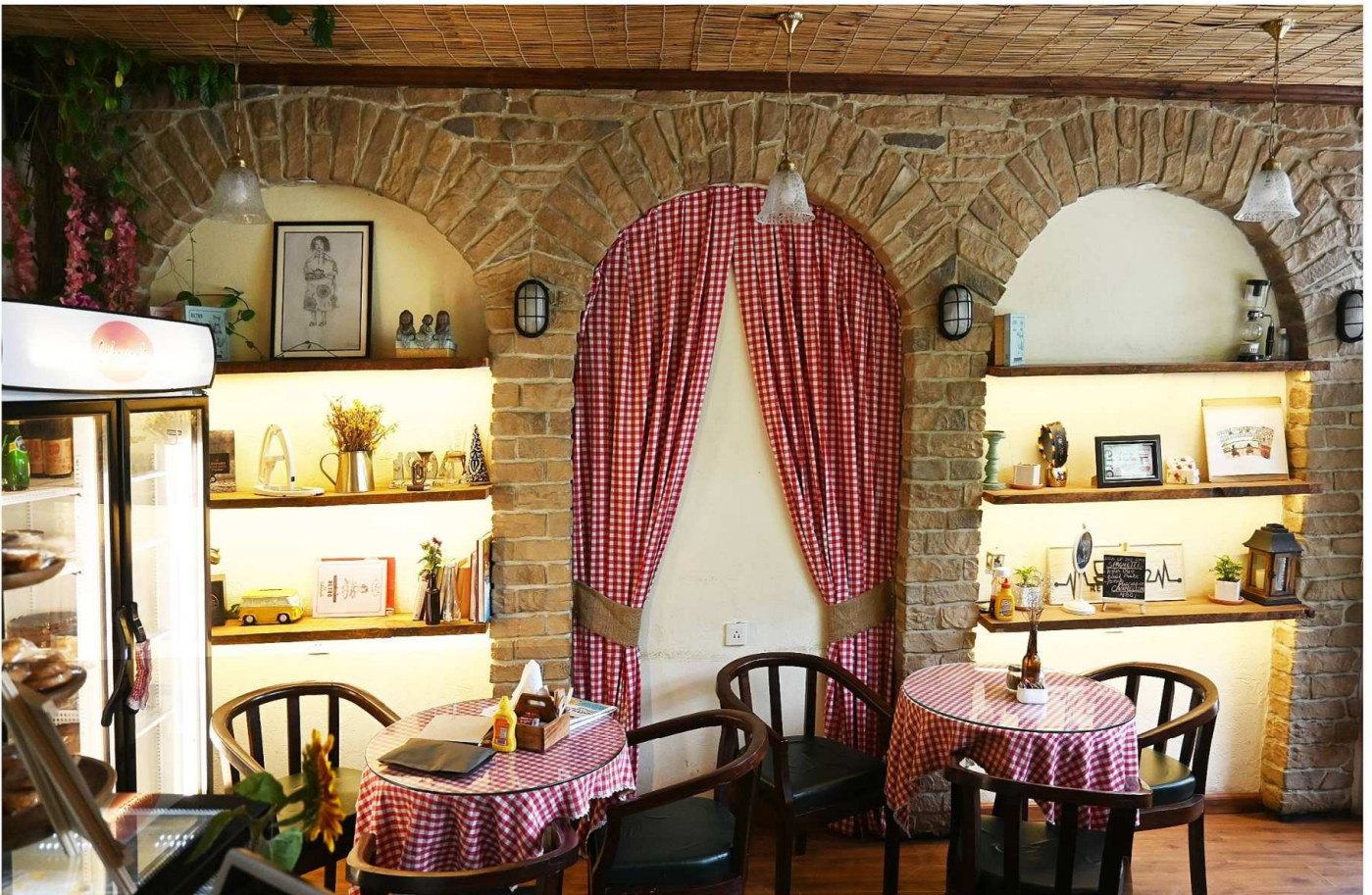
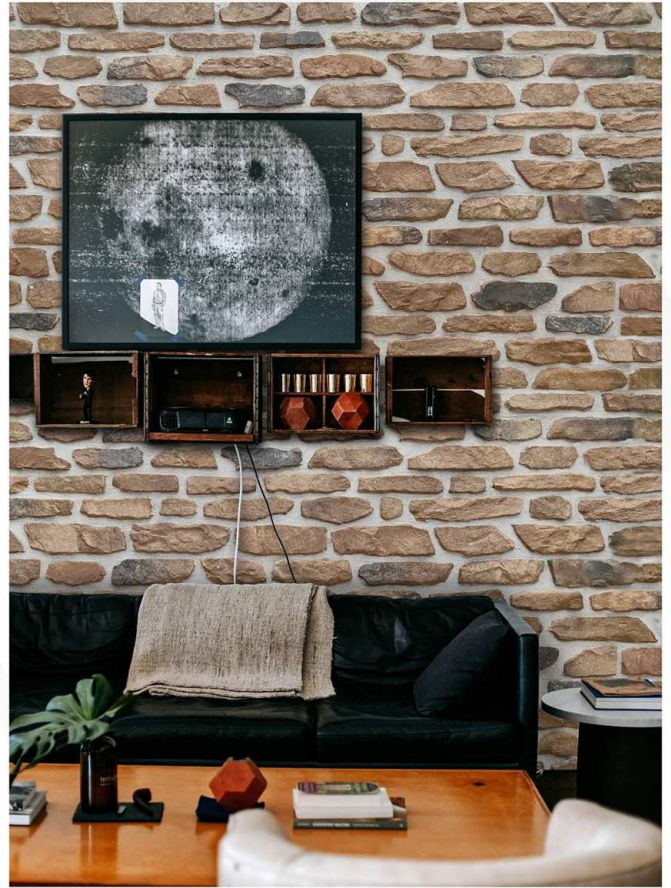



GRAND CANYON-SOLANO BROWN



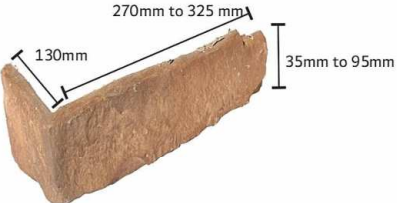

GRAND CANYON-SOLANO BROWN

SPECIFICATION (GRAND CANYON)



Flat Stone	Corner Stone	Thickness
 <p>Weight of stone: 2.2 kg per sq. ft. (Approx.)</p>	 <p>Area covered per running feet= 1 sq. ft.</p>	 <p>15mm to 20mm</p>

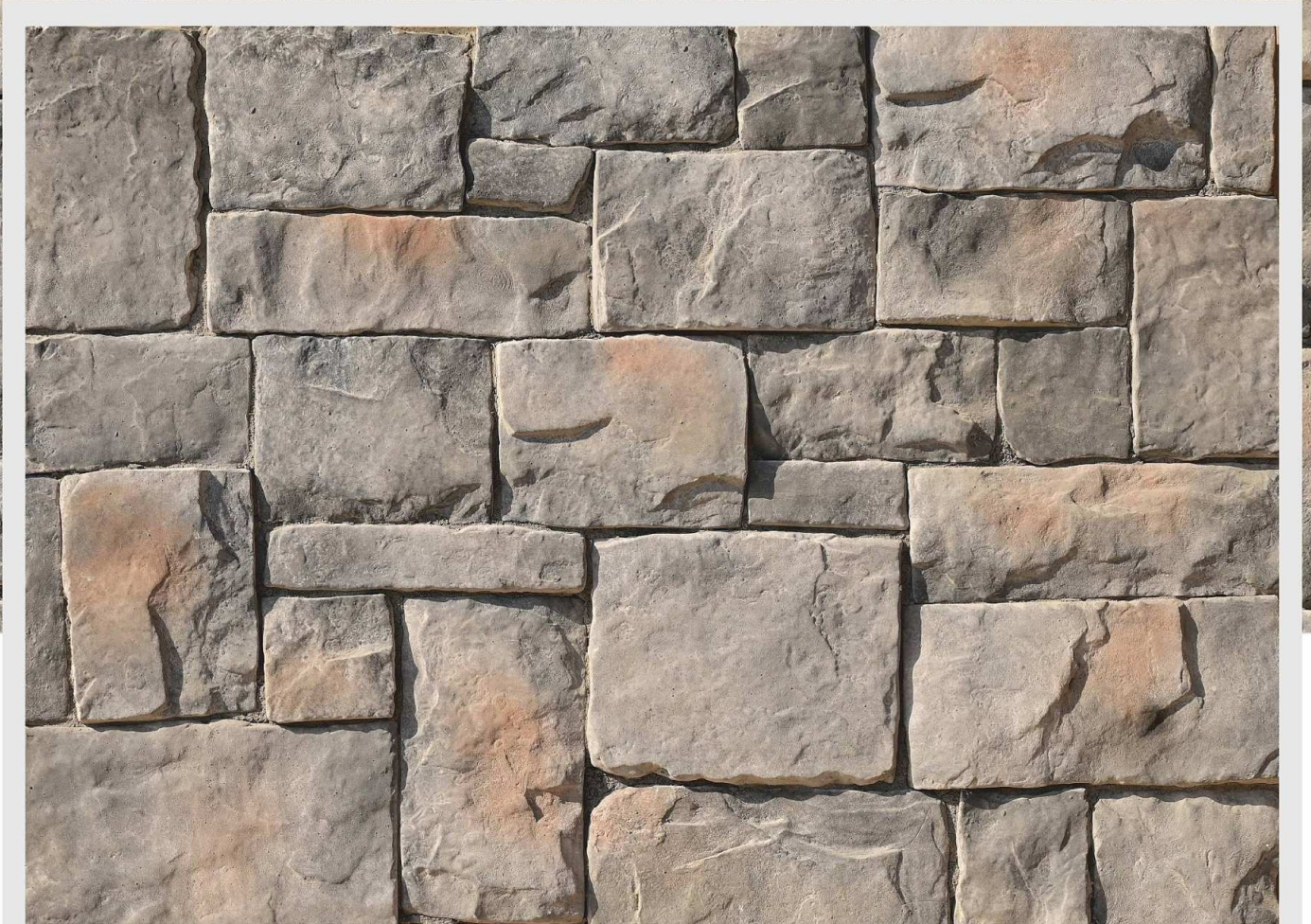

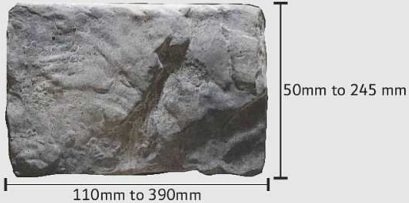
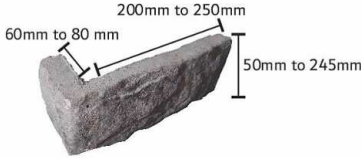

EUROPEAN CASTLE-MISTY GREY

**SPECIFICATION (EUROPEAN LEDGE)**

Flat Stone	Corner Stone	Thickness
 <p>Weight of stone: 3.75 kg per sq. ft (Approx.)</p>	 <p>Area covered per running feet= 1.00 sq. ft.</p>	

**EUROPEAN CASTLE**



# COUNTRY LEDGE



COASTAL CREAM



MISTY GREY

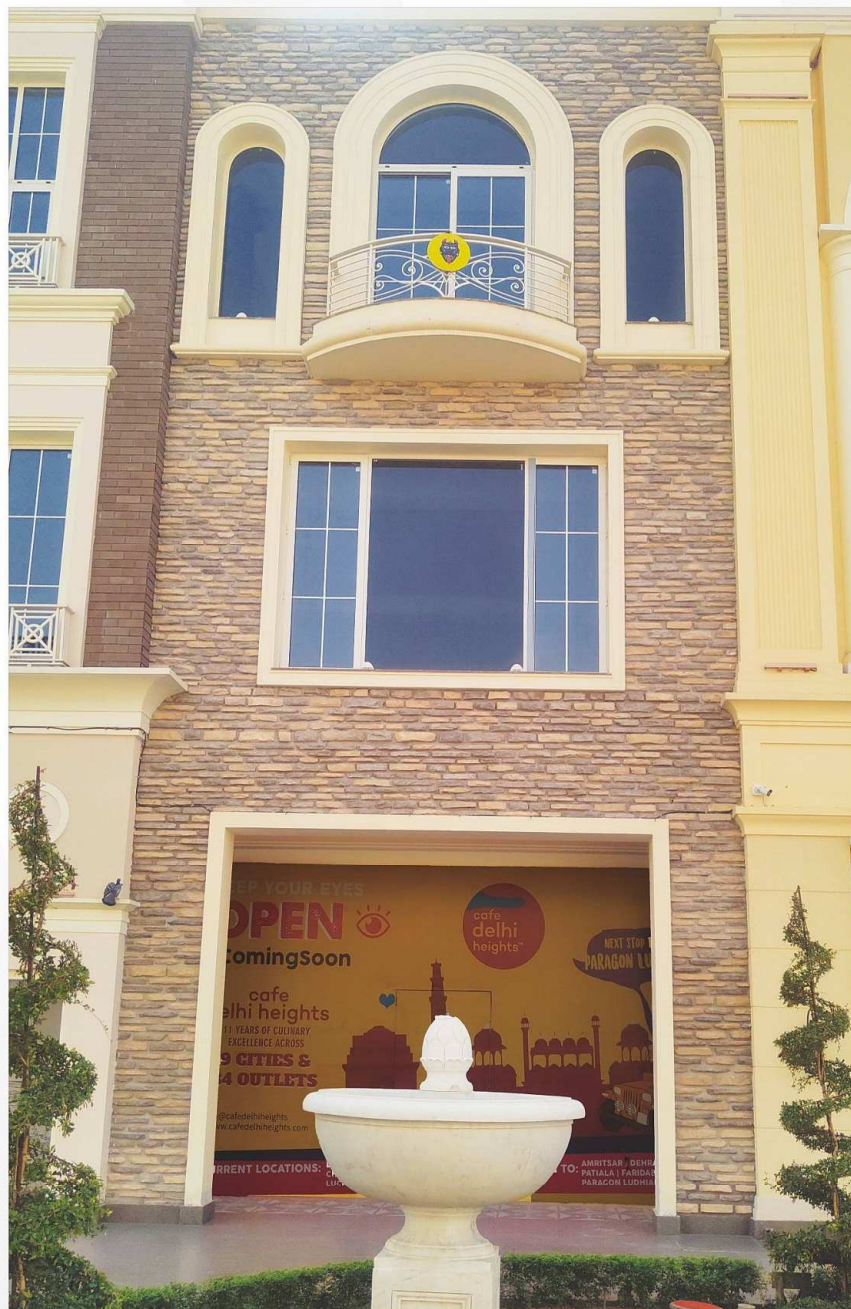

COUNTRY LEDGE-COASTAL CREAM







MANUFACTURED ARCHITECTURAL STONE CLADDINGS

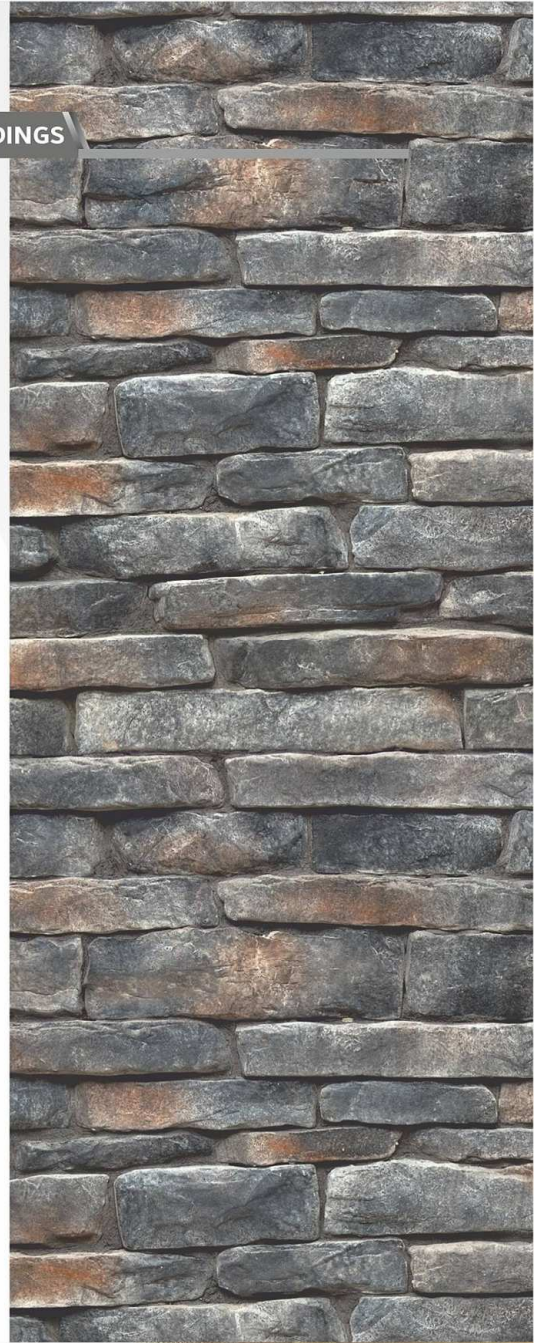

COUNTRY LEDGE-MISTY GREY





MANUFACTURED ARCHITECTURAL STONE CLADDINGS

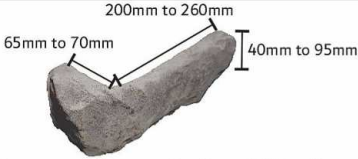

COUNTRY LEDGE-MISTY GREY

SPECIFICATION (COUNTRY LEDGE)

Flat Stone	Corner Stone	Thickness
 <p>Weight of stone: 3.5 kg per sq. ft (Approx.)</p>	 <p>Area covered per running feet= 1.12 sq. ft.</p>	 <p>45mm to 50mm</p>



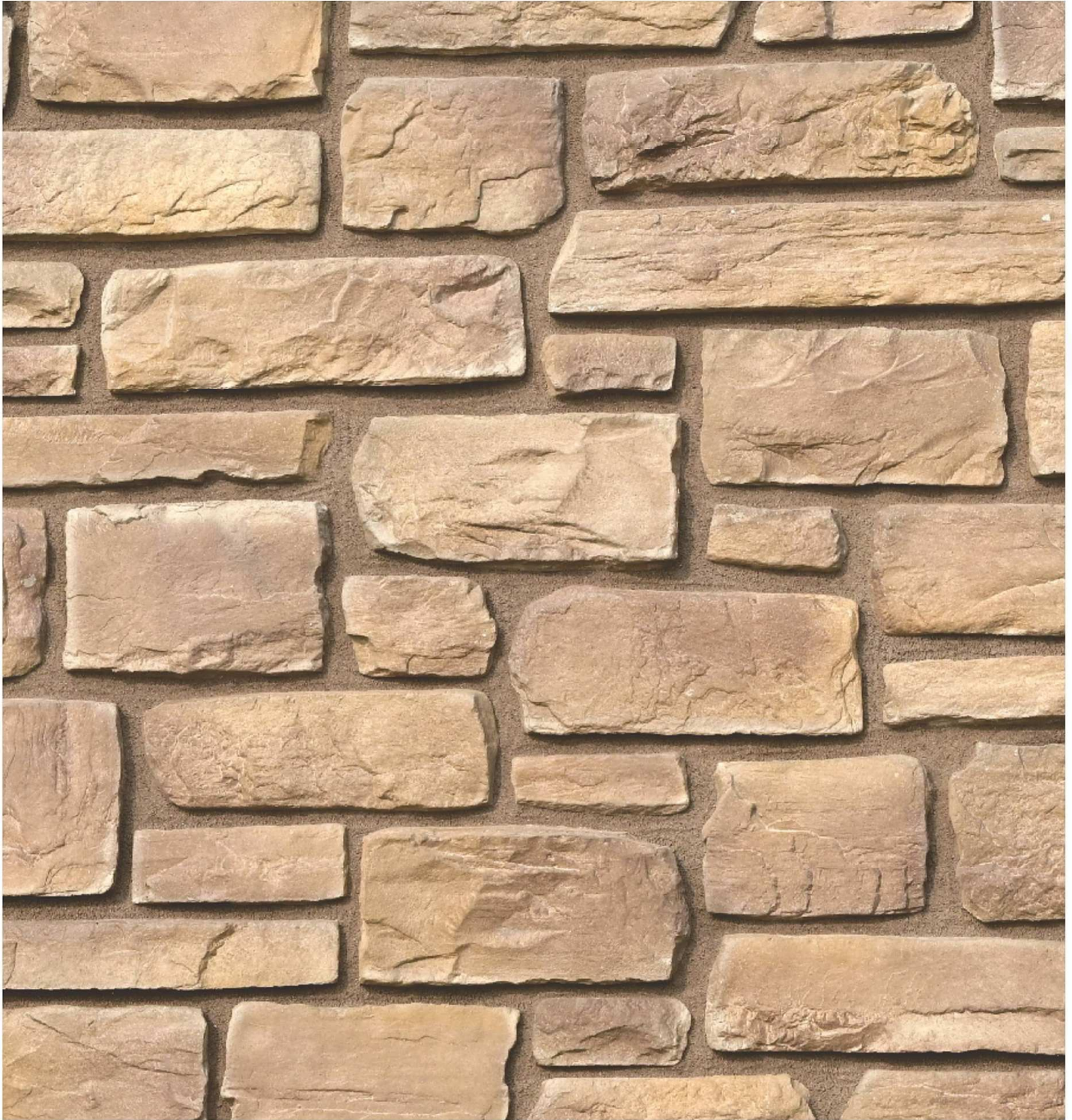

# ITALIAN VILLA

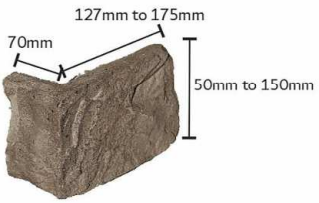

NUT BROWN

## SPECIFICATION (ITALIAN VILLA)

Flat Stone		Corner Stone	Thickness
 <p>Weight of stone: 3 kg per sq. ft. (Approx.)</p>		 <p>Area covered per running feet= 0.70 sq. ft.</p>	
Area Per Box (sq.ft.)	9.15		
Weight Per Box (kgs.)	30		



# RUBBLE STONE



RUBBLE STONE-MISTY GREY



RUBBLE STONE-CAIRO

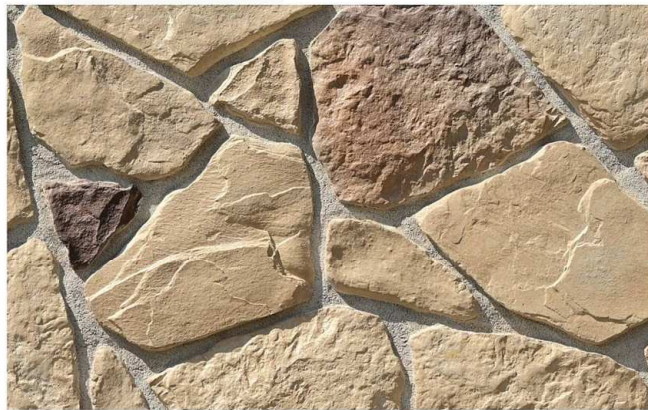

RUBBLE STONE-COASTAL CREAM





**RUBBLE STONE-MISTY GREY**







**RUBBLE STONE-CAIRO**

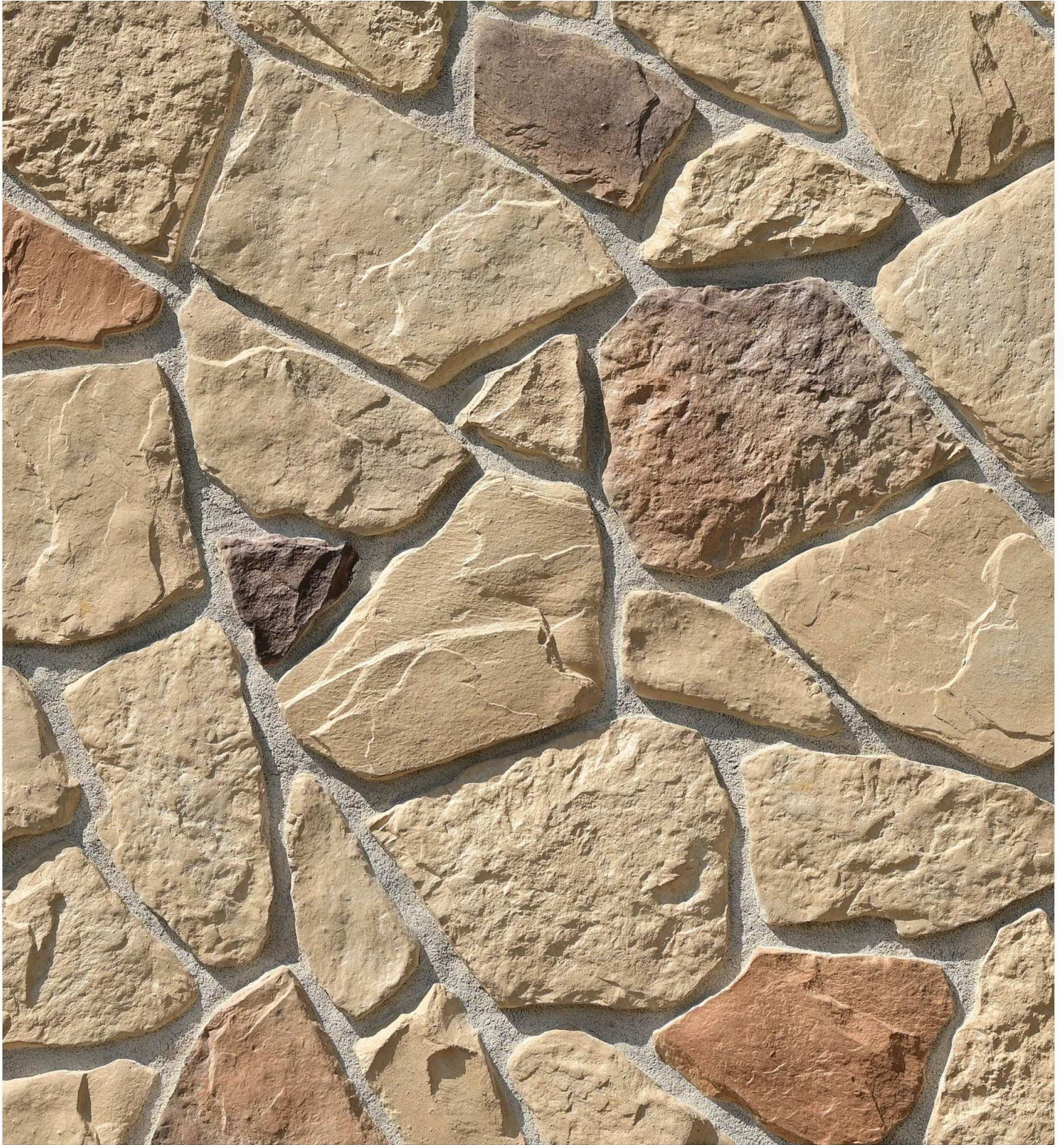

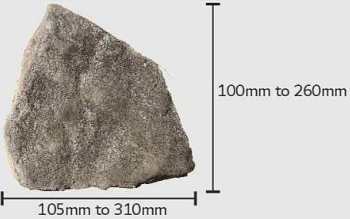
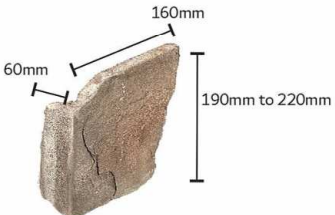

## RUBBLE STONE-COASTAL CREAM

### SPECIFICATION (RUBBLE STONE)

Flat Stone		Corner Stone	Thickness
 <p>105mm to 310mm</p> <p>100mm to 260mm</p> <p>Weight of stone: 3 kg per sq. ft. (Approx.)</p>		 <p>60mm</p> <p>160mm</p> <p>190mm to 220mm</p> <p>Area covered per running feet= 0.70 sq. ft.</p>	 <p>20mm to 30mm</p>
Area Per Box (sq.ft.)	9.00		



# IMPERIAL CASTLE



**RAINFOREST**



**SILVERTON**



**CANYON GREY**



**PEARL**



**MISTY GREY**



**OYSTER**



**ARCTIC WHITE**



**ASHLAR**



MANUFACTURED ARCHITECTURAL STONE CLADDINGS

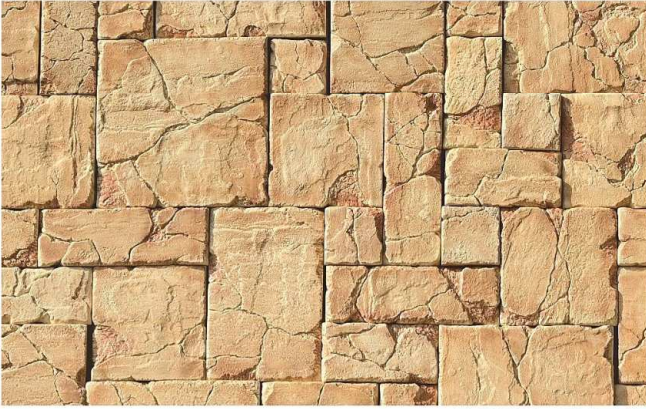

**ROYAL AMBER**



**IMPERIAL CASTLE-ROYAL AMBER**



MANUFACTURED ARCHITECTURAL STONE CLADDINGS



IMPERIAL CASTLE-ROYAL AMBER



MANUFACTURED ARCHITECTURAL STONE CLADDINGS



IMPERIAL CASTLE-PEARL

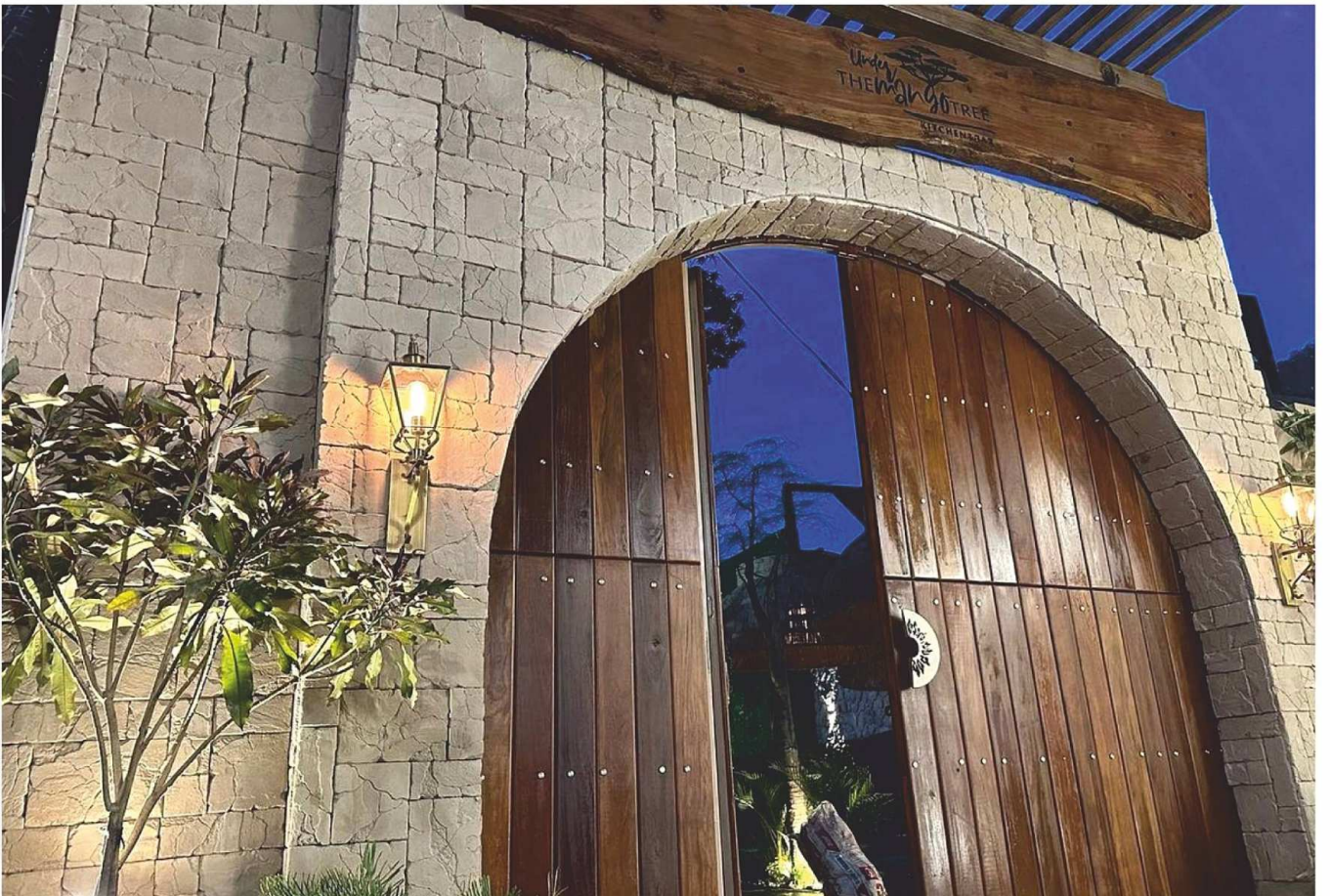

IMPERIAL CASTLE-SILVERTON





IMPERIAL CASTLE-PEARL







IMPERIAL CASTLE-PEARL



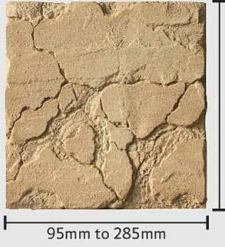
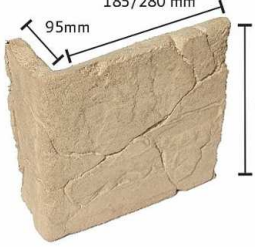

IMPERIAL CASTLE-ARCTIC WHITE

SPECIFICATION (IMPERIAL CASTLE)

Flat Stone	Corner Stone	Thickness
 <p>95mm to 285mm</p> <p>95mm to 285mm</p> <p>Weight of stone: 3.4 kg per sq. ft (Approx.)</p>	 <p>185/280 mm</p> <p>95mm</p> <p>95mm to 285mm</p> <p>Area covered per running feet= 1.1 sq. ft.</p>	 <p>20mm to 30mm</p>



# SIERRA CUT



COASTAL CREAM



SILVERTON



PEARL



RAINFOREST

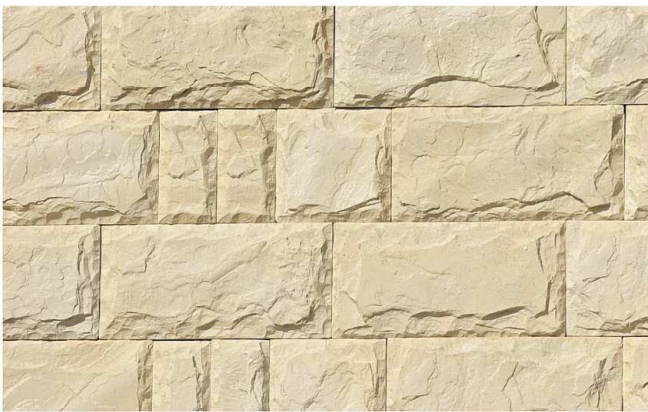

OYSTER



ASHLAR



ARCTIC WHITE



BLACK RIVER



MANUFACTURED ARCHITECTURAL STONE CLADDINGS



**SIERRA CUT-COASTAL CREAM**



MANUFACTURED ARCHITECTURAL STONE CLADDINGS

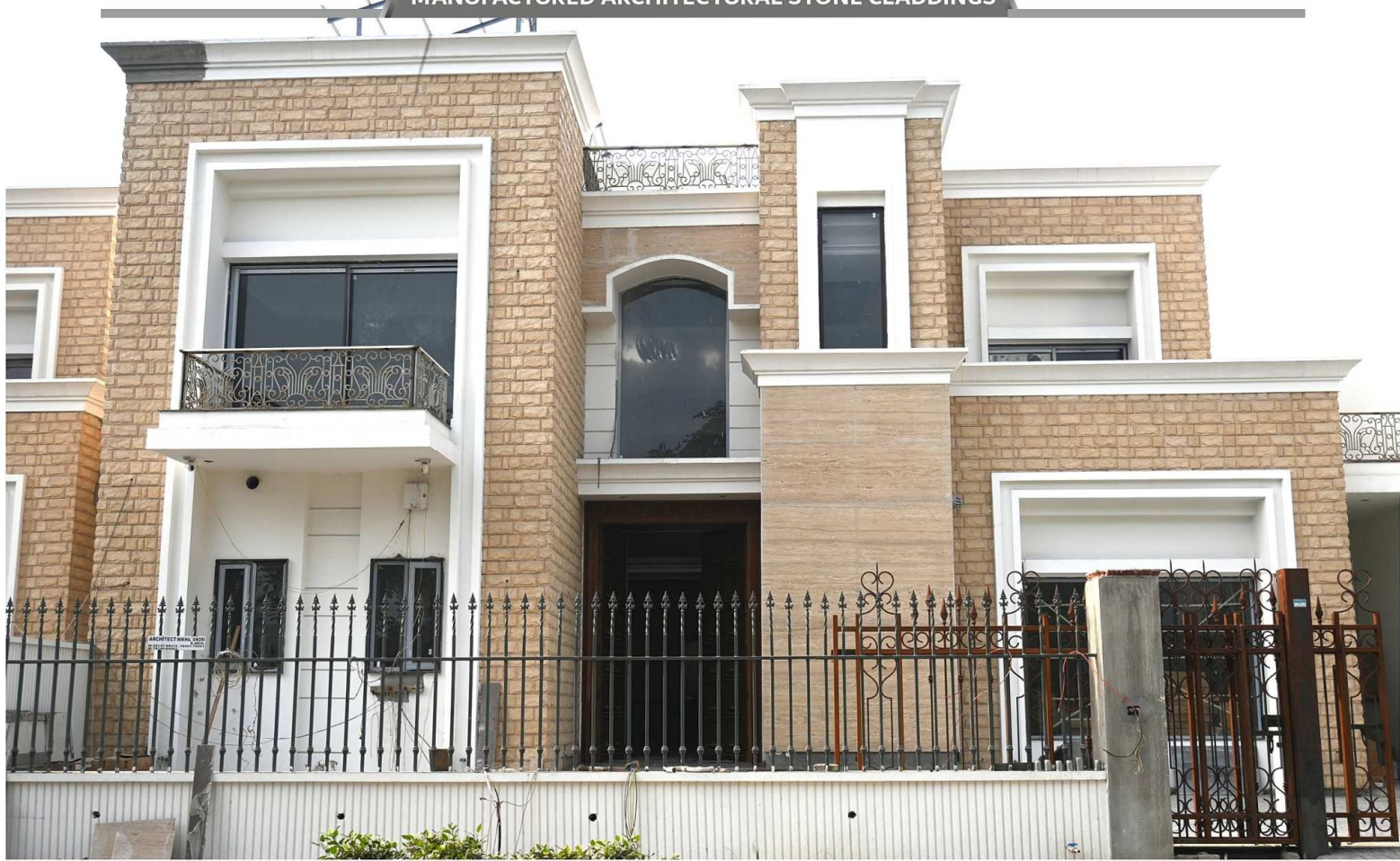

SIERRA CUT-COASTAL CREAM



MANUFACTURED ARCHITECTURAL STONE CLADDINGS

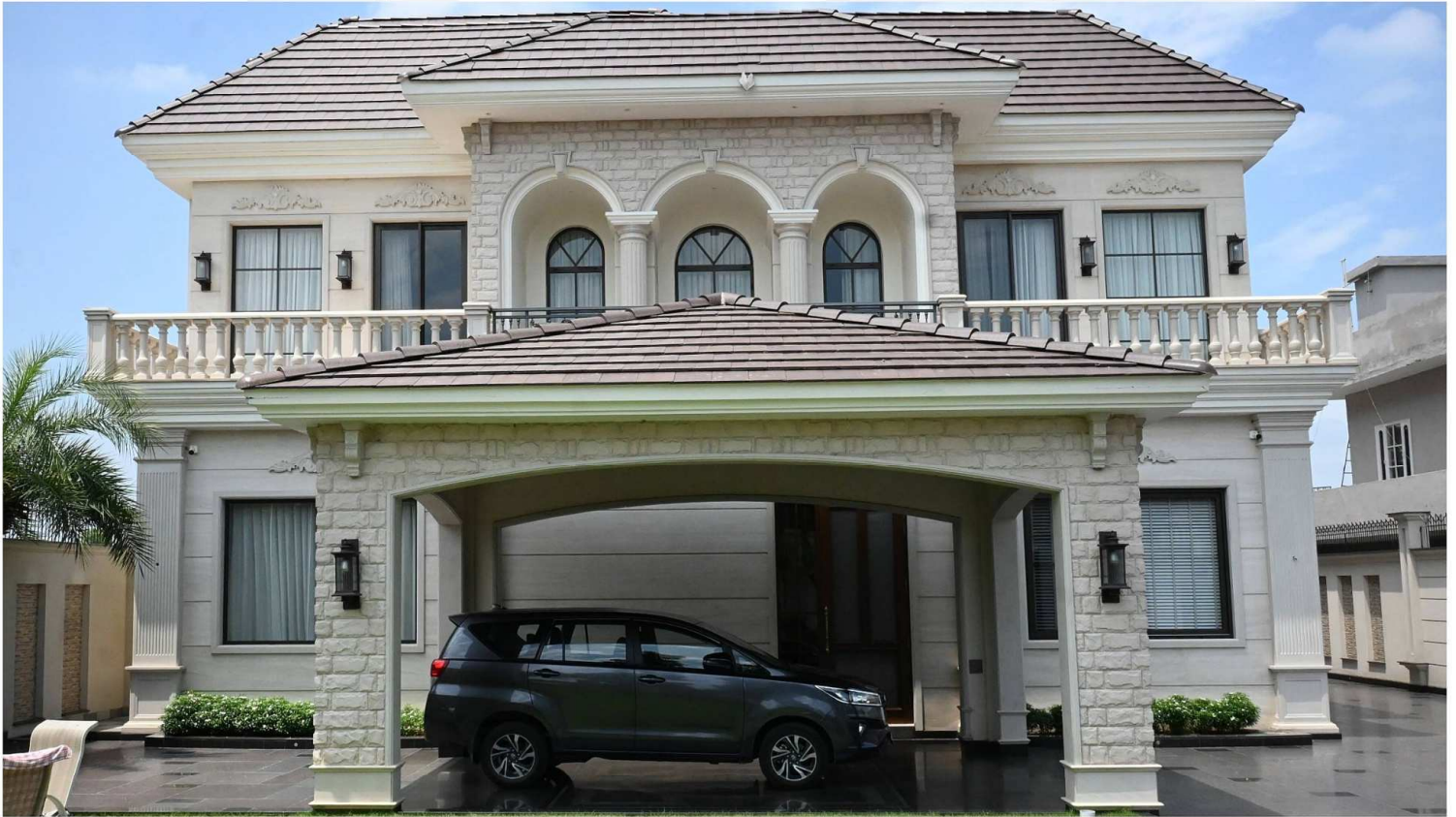

SIERRA CUT-SILVERTON





SIERRA CUT-PEARL

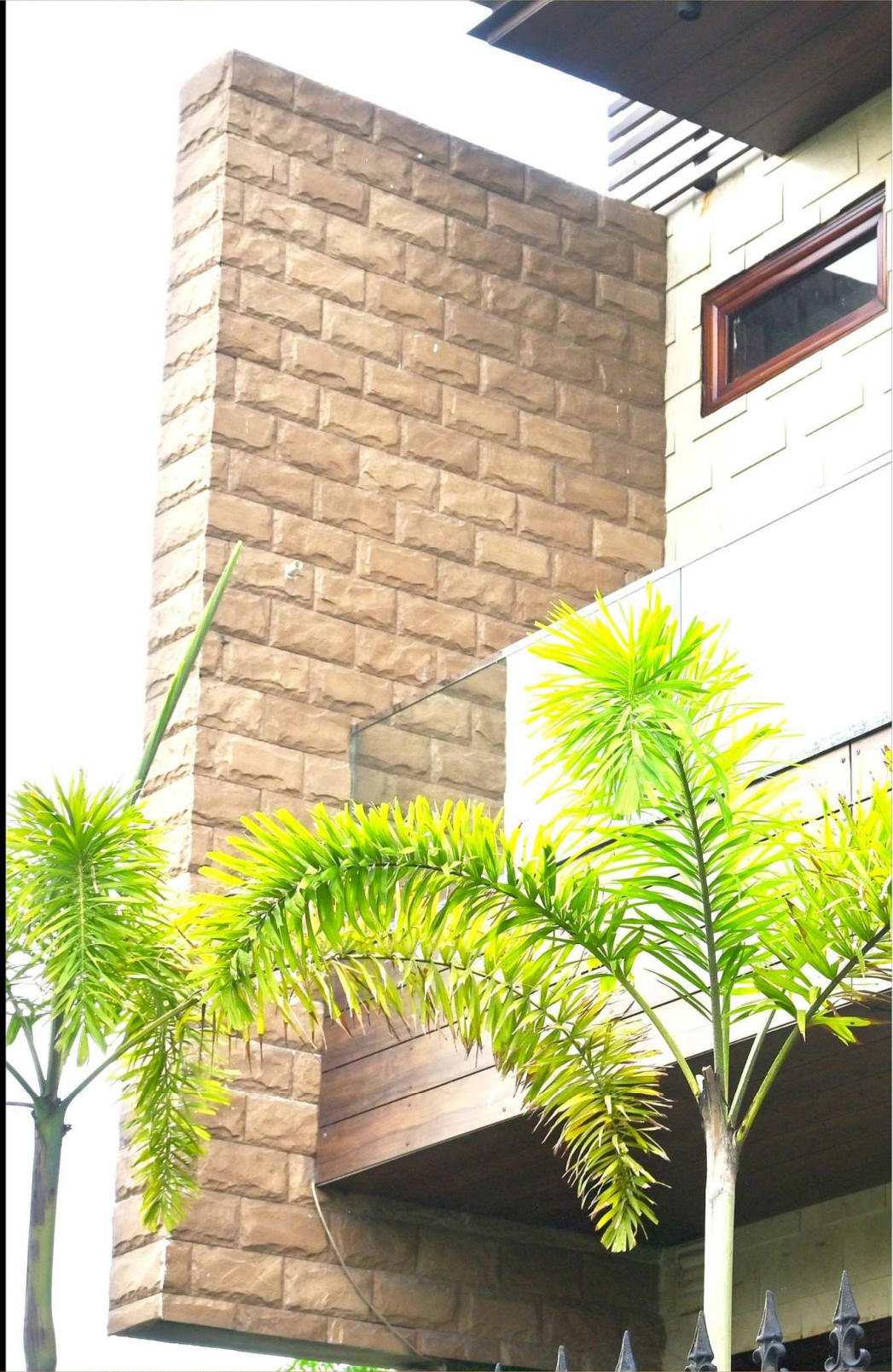



# SIERRA CUT-ASHLAR





**MANUFACTURED ARCHITECTURAL STONE CLADDINGS**



**SIERRA CUT-PEARL**





MANUFACTURED ARCHITECTURAL STONE CLADDINGS

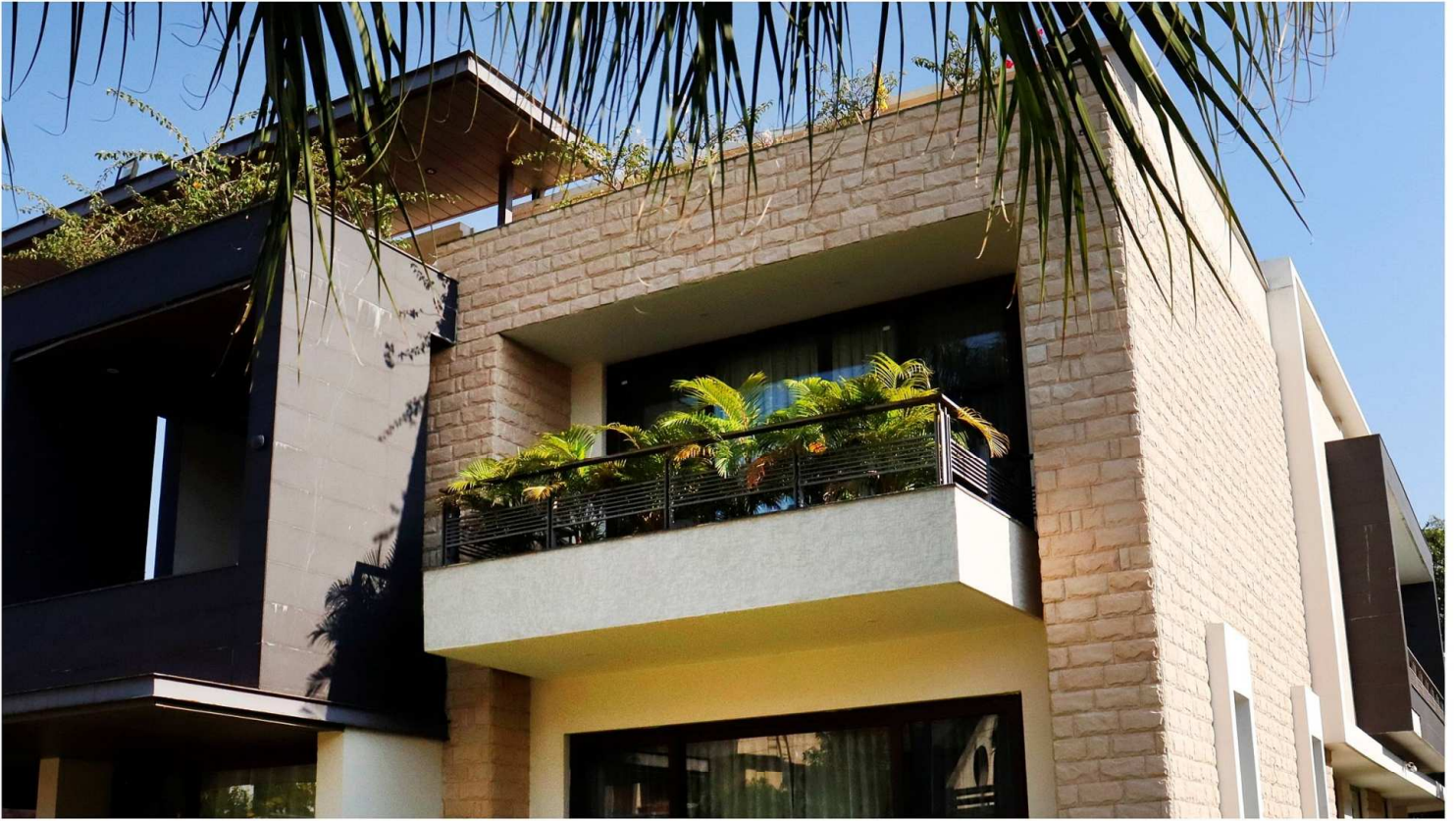

SIERRA CUT-OYSTER







SIERRA CUT-OYSTER



# GRIT STONE



LUXOR



RAINFOREST



SILVERTON



CAIRO



COASTAL CREAM



MANUFACTURED ARCHITECTURAL STONE CLADDINGS

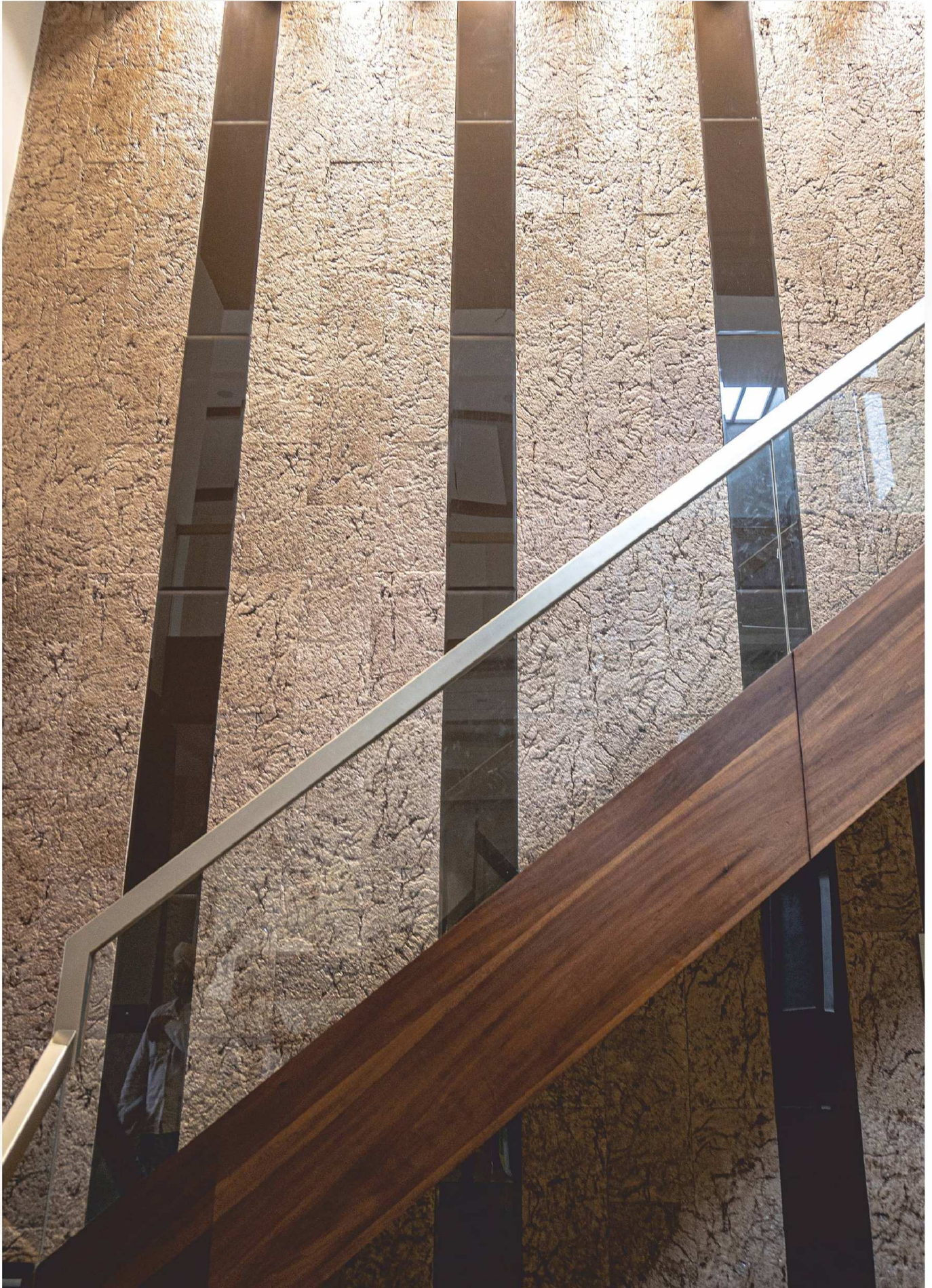

GRIT STONE-LUXOR





MANUFACTURED ARCHITECTURAL STONE CLADDINGS



GRIT STONE-SILVERTON

SPECIFICATION (GRIT STONE)

Flat Stone	Thickness
 <p data-bbox="488 1939 847 1966">Weight of stone: 4 kg per sq. ft (Approx.)</p>	



MANUFACTURED ARCHITECTURAL STONE CLADDINGS



GRIT STONE-LUXOR



# CLIFF STONE



COASTAL CREAM

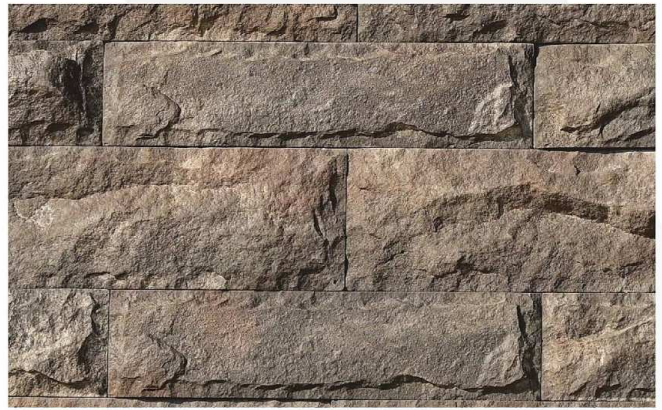

RAINFOREST



CAIRO



BLACK RIVER

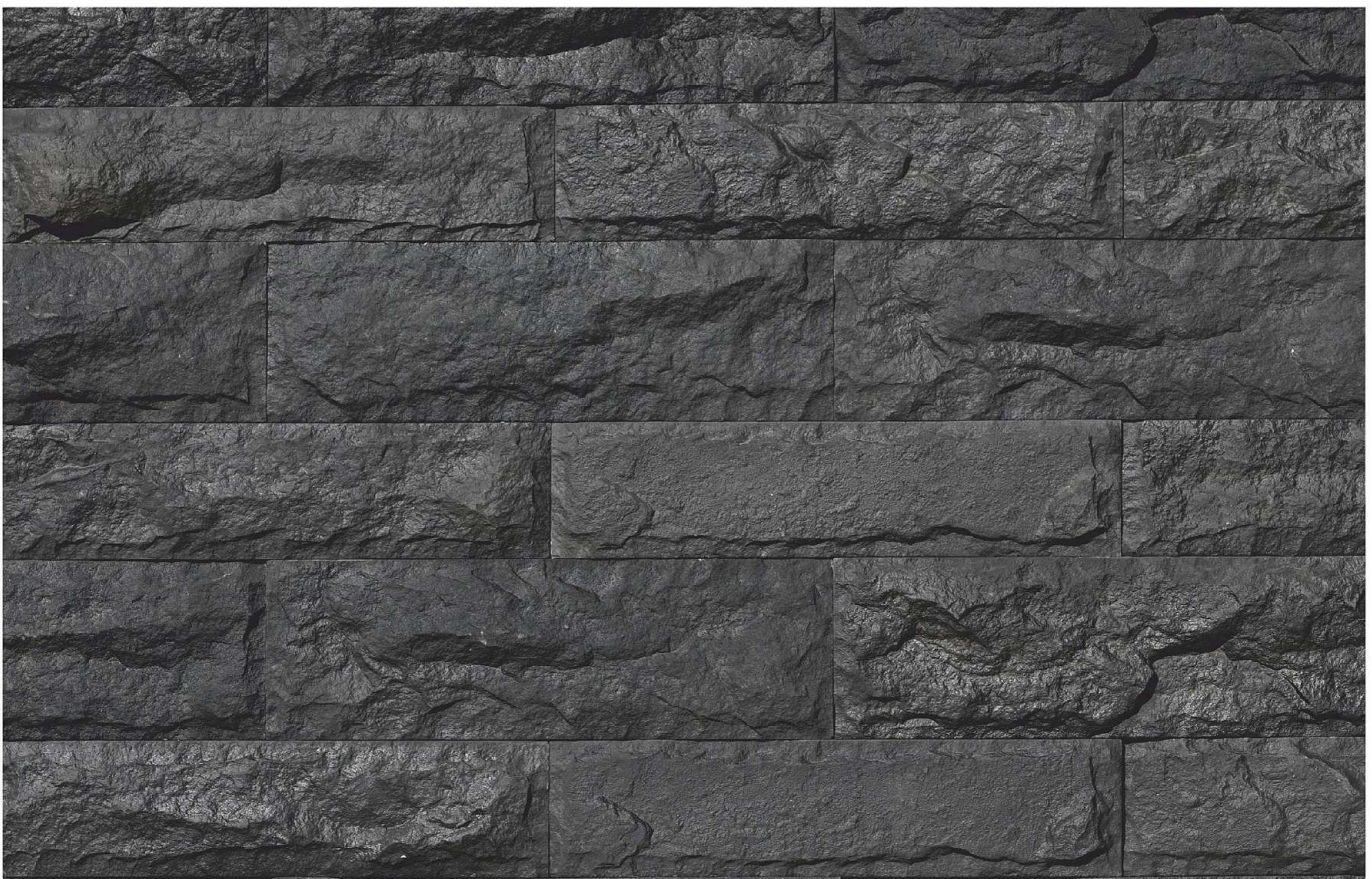

CLIFF STONE-BLACK RIVER



MANUFACTURED ARCHITECTURAL STONE CLADDINGS

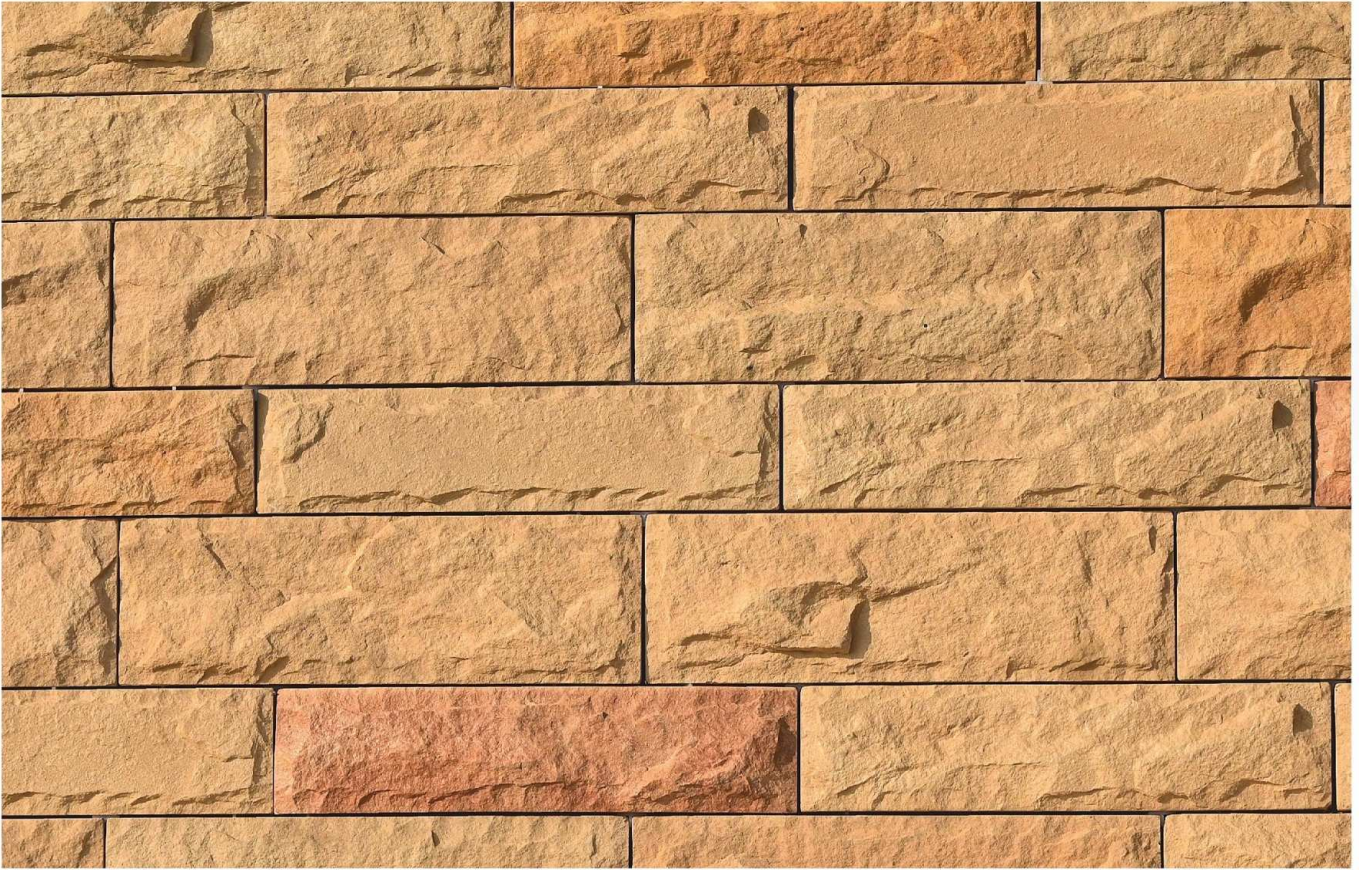

**CLIFF STONE-COASTAL CREAM**

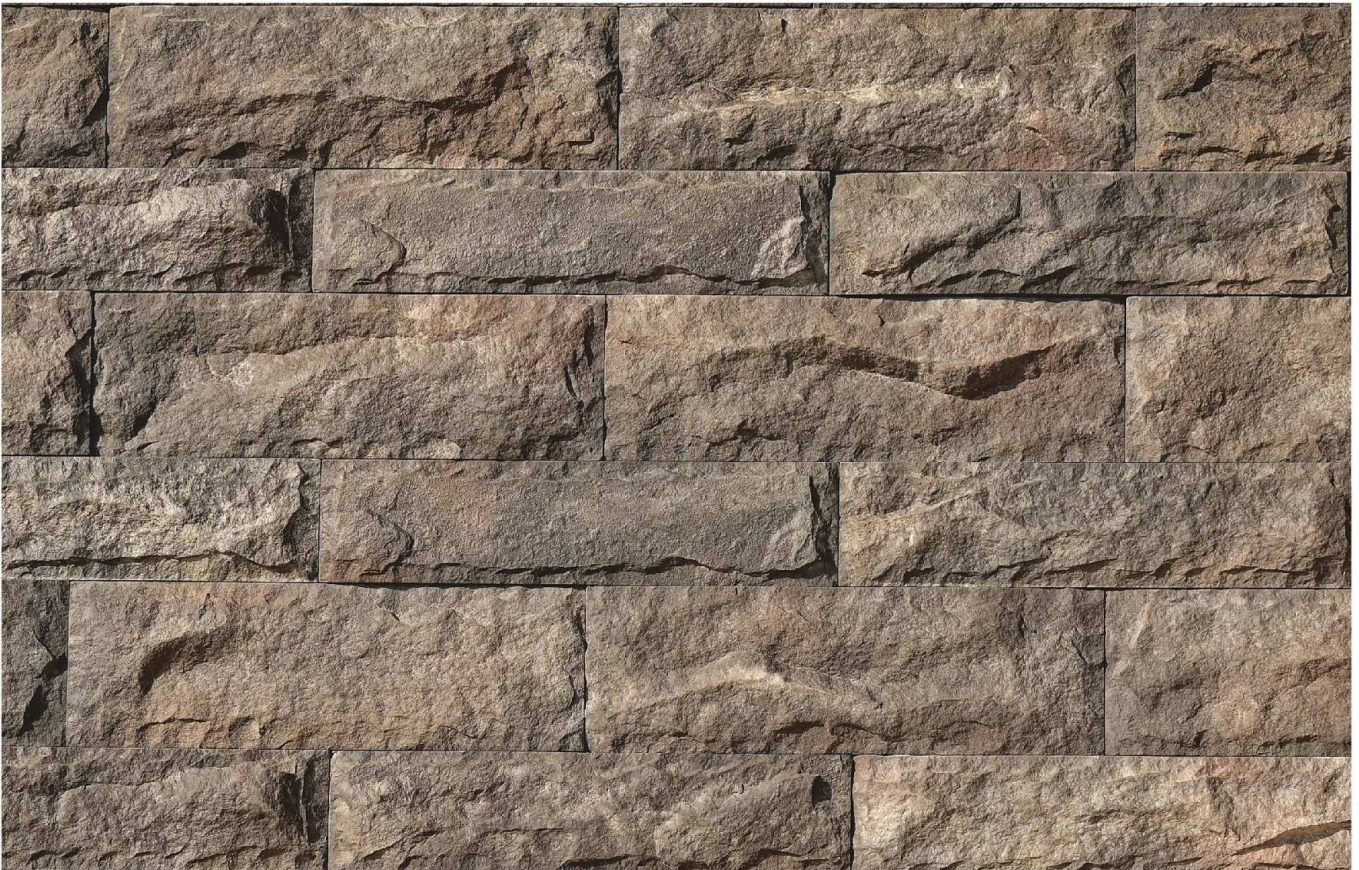

**CLIFF STONE-RAINFOREST**





MANUFACTURED ARCHITECTURAL STONE CLADDINGS



CLIFF STONE-CAIRO

SPECIFICATION (CLIFF STONE)

Flat Stone	Thickness
 <p>600mm</p> <p>150mm/200mm</p> <p>Weight of stone: 4.5 kg per sq. ft (Approx.)</p>	 <p>25mm to 65mm</p>

CHEQUERED CUT STONE



SILVERTON



HIGHLAND CREAM











CHEQUERED CUT STONE-SILVERTON





CHEQUERED CUT STONE-HIGHLAND CREAM

SPECIFICATION (CHEQUERED CUT STONE)

Flat Stone	Thickness
 <p>385mm</p> <p>105mm</p> <p>Weight of stone: 2.4 kg per sq. ft (Approx.)</p>	 <p>15mm to 20mm</p>



# ROMAN BRICK

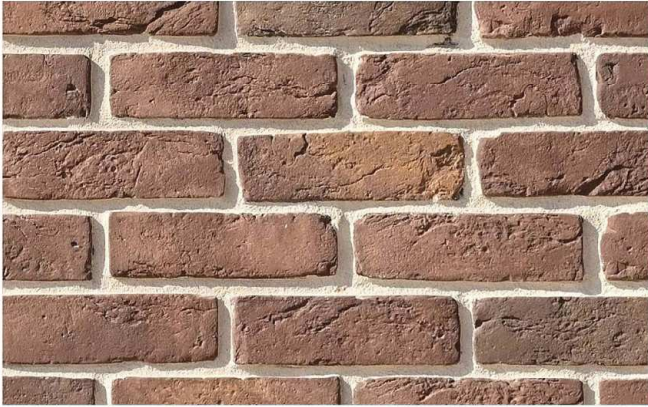

CASABLANCA



MERLOT

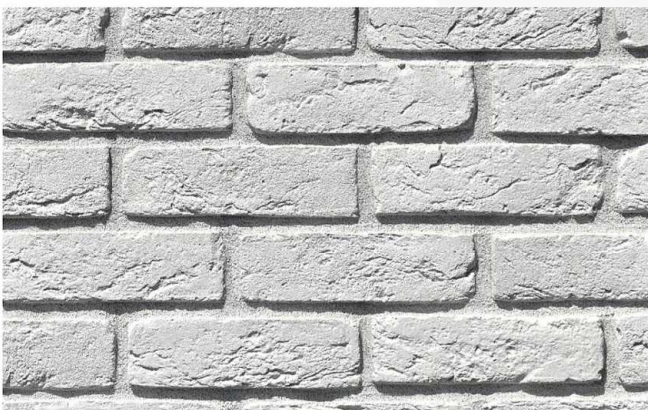

SANTORINI



BLACK FOREST



AUTUMN



MOROCCAN SAND

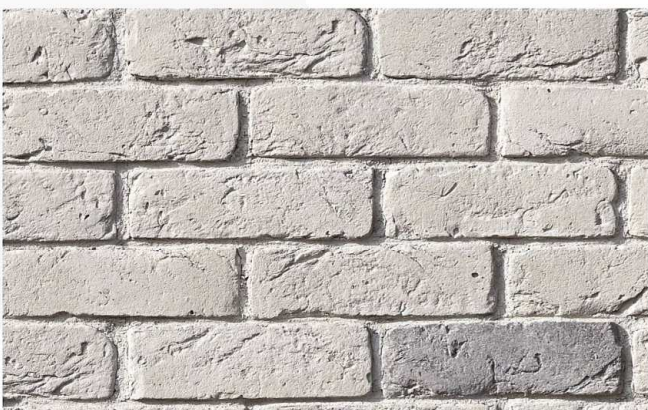

ARCTIC WHITE



BROOKLYN



MANUFACTURED ARCHITECTURAL STONE CLADDINGS



ROMAN BRICK-ARCTIC WHITE

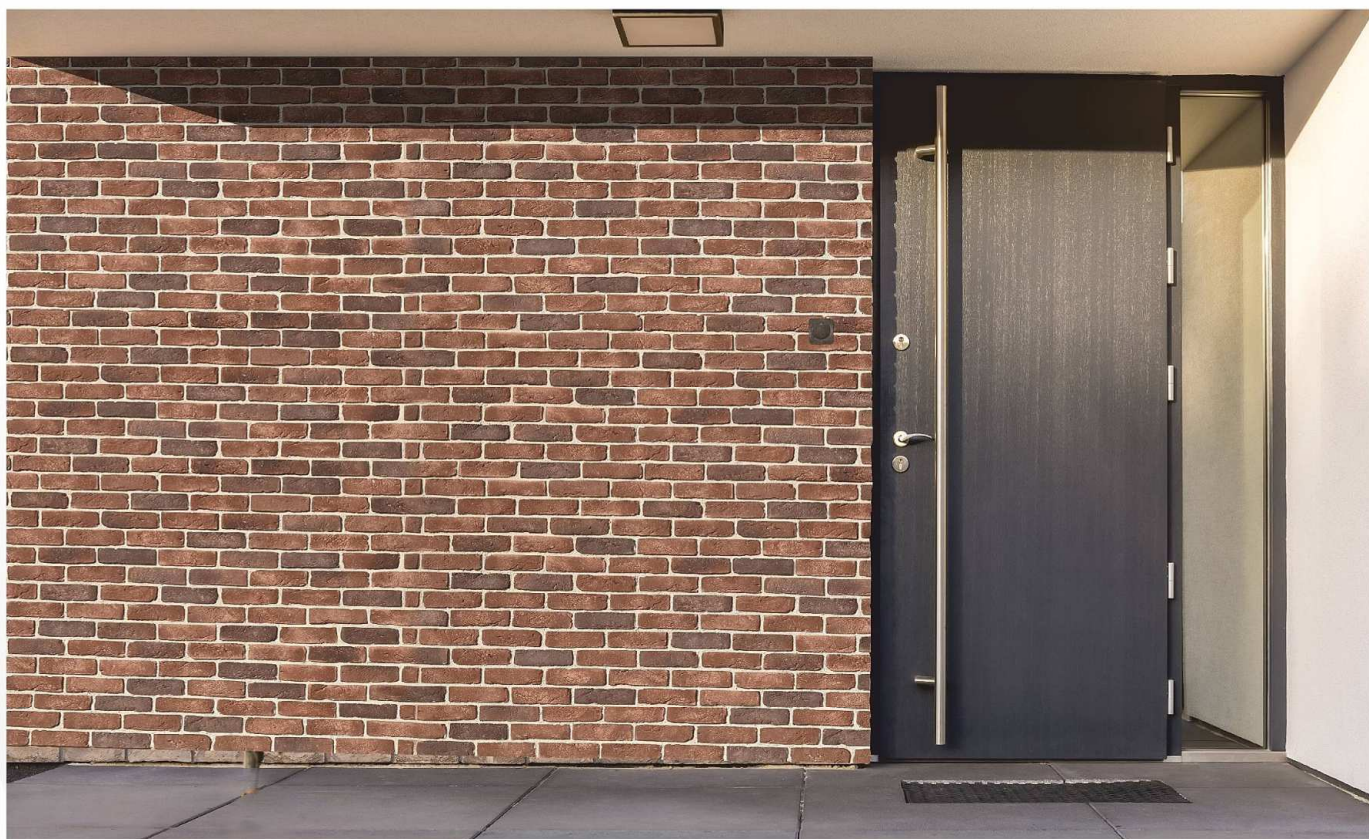

ROMAN BRICK-MERLOT



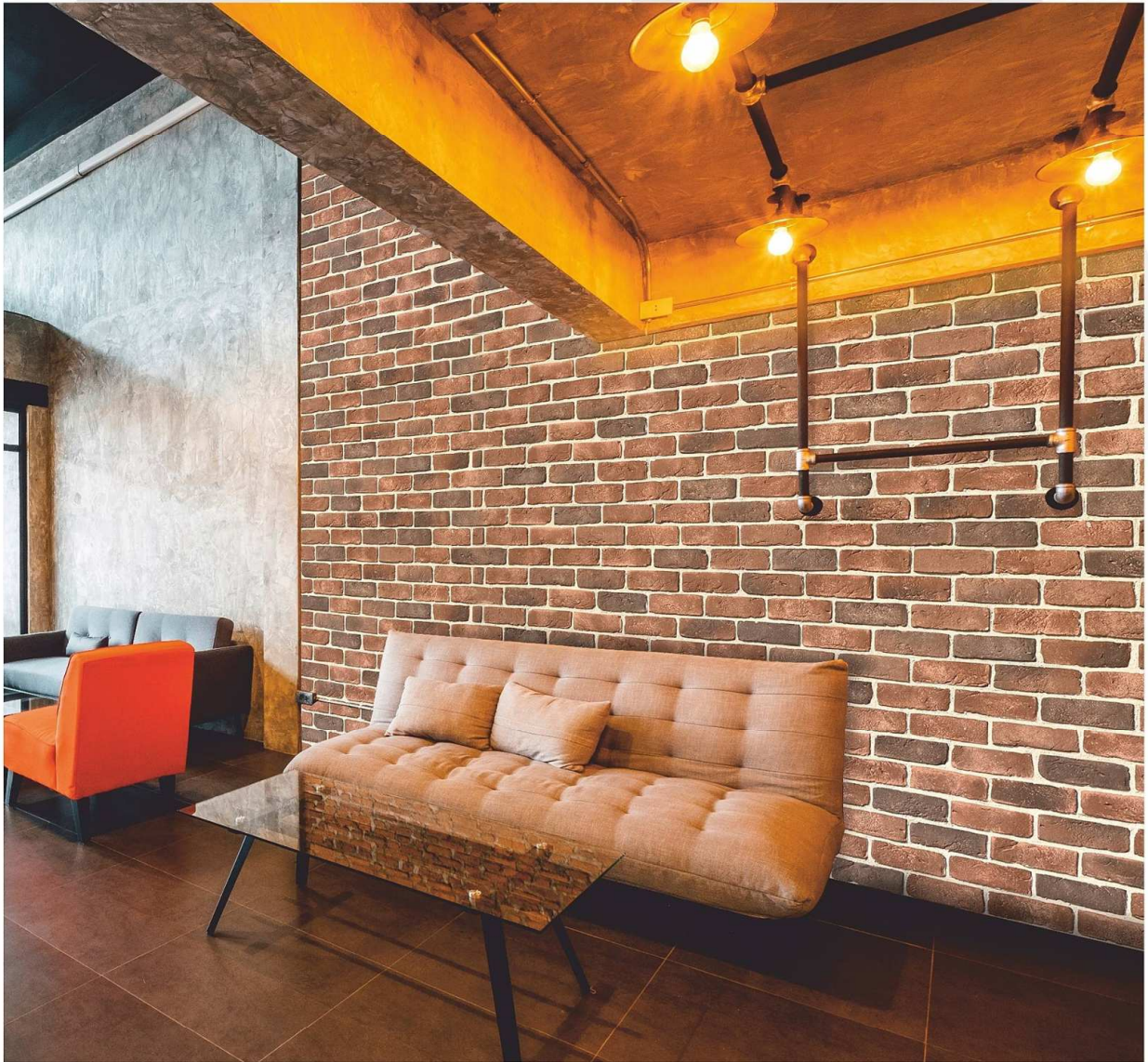

MANUFACTURED ARCHITECTURAL STONE CLADDINGS

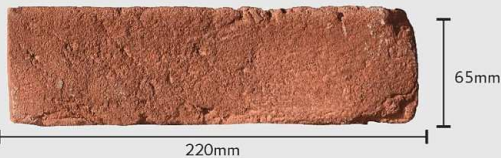
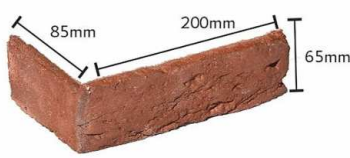

ROMAN BRICK-MERLOT

SPECIFICATION (ROMAN BRICK)

Flat Stone	Corner Stone	Thickness
 <p>Weight of stone: 2 kg per sq. ft (Approx.)</p>	 <p>Area covered per running feet= 0.93 sq. ft.</p>	 <p>10mm to 15mm</p>



# LAKHORI BRICK

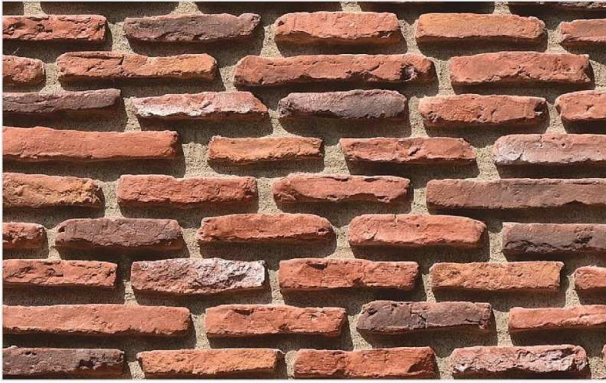

CLASSIC RED

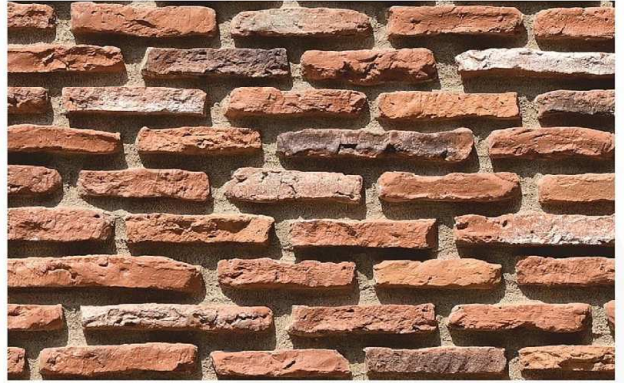

CLASSIC ORANGE



ADOBE

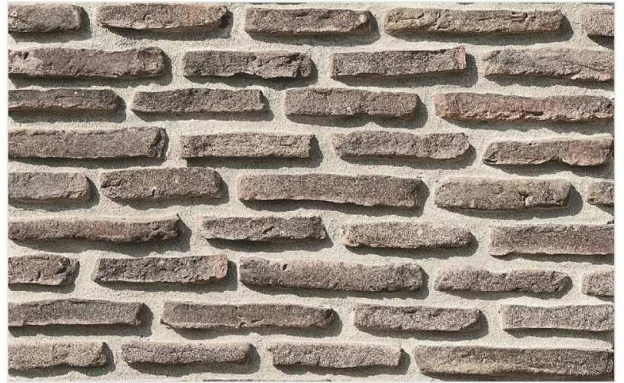

MISTY GREY



LAKHORI BRICK-CLASSIC RED

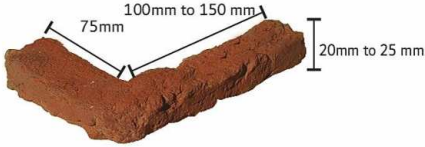
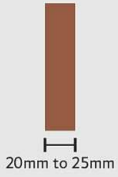

SPECIFICATION (LAKHORI BRICK)

Flat Stone	Corner Stone	Thickness
 <p>Weight of stone: 4 kg per sq. ft. (Approx.)</p>	 <p>Area covered per running feet= 0.70 sq. ft.</p>	 <p>20mm to 25mm</p>

NEW COLLECTION

URBAN BRICK

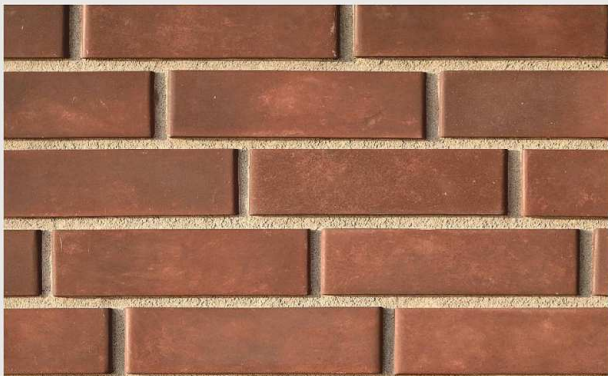

CHERRY



ASH GREY



CLINKERED WHITE



COFFEE BROWN

SPECIFICATION (URBAN BRICK)

Flat Stone	Thickness
 <p>Weight of stone: 2 kg per sq. ft. (Approx.)</p>	 <p>10mm to 15mm</p>



# TERRA BRICK

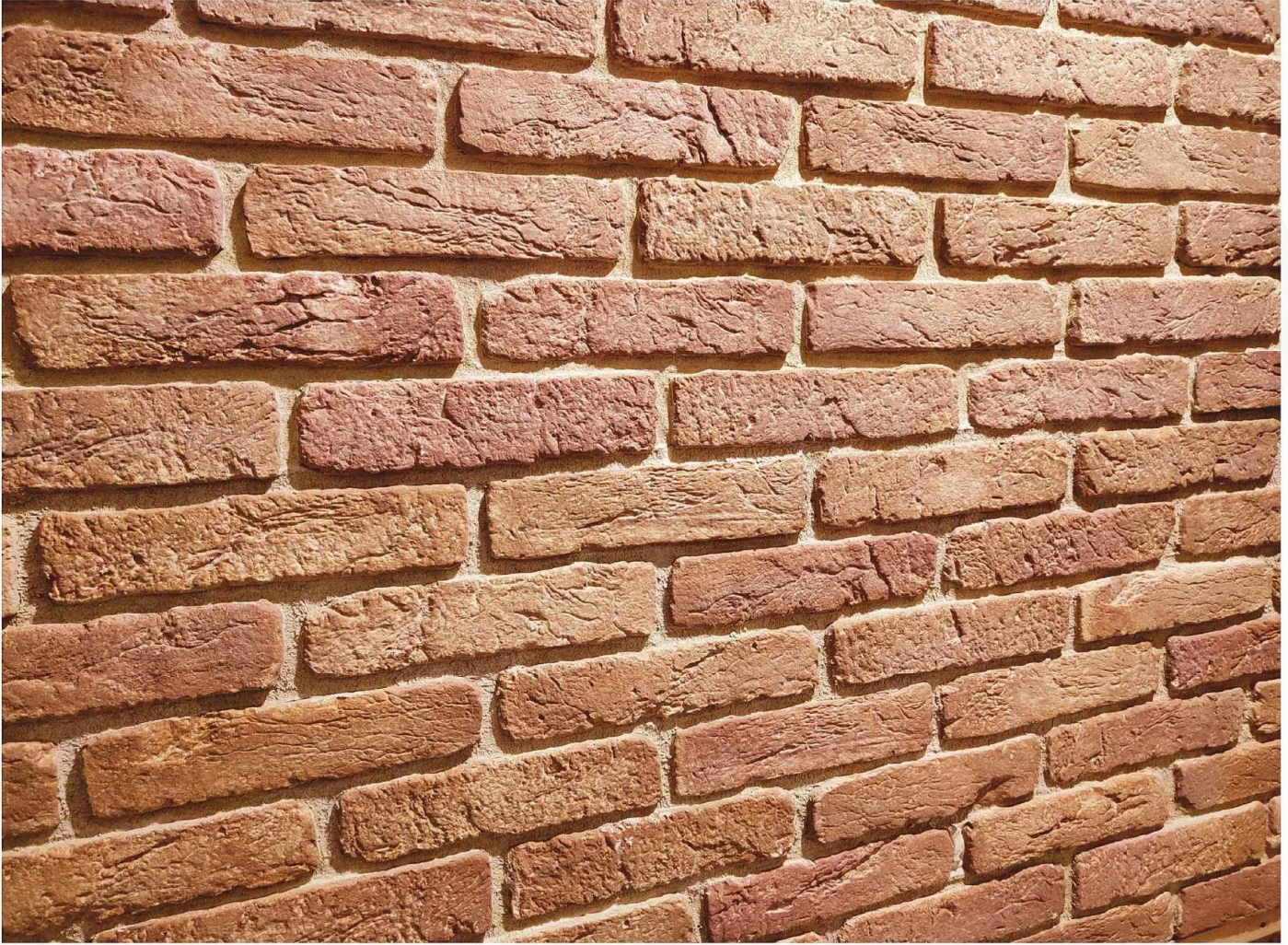

TERRA BRICK-HIGHLAND CREAM

## SPECIFICATION (TERRA BRICK)

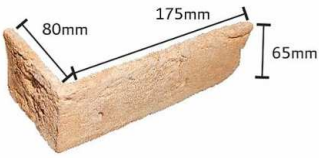
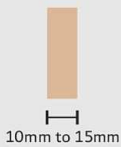
Flat Stone	Corner Stone	Thickness
 <p>290mm</p> <p>65mm</p> <p>Weight of stone: 2 kg per sq. ft (Approx.)</p>	 <p>80mm</p> <p>175mm</p> <p>65mm</p> <p>Area covered per running feet= 0.84 sq. ft.</p>	 <p>10mm to 15mm</p>





**BARN WOOD-VINTAGE**



**BARN WOOD-ARCTIC WHITE**



**BARN WOOD-COUNTRYSIDE**



**BARN WOOD-COASTAL CREAM**

**BARN WOOD**



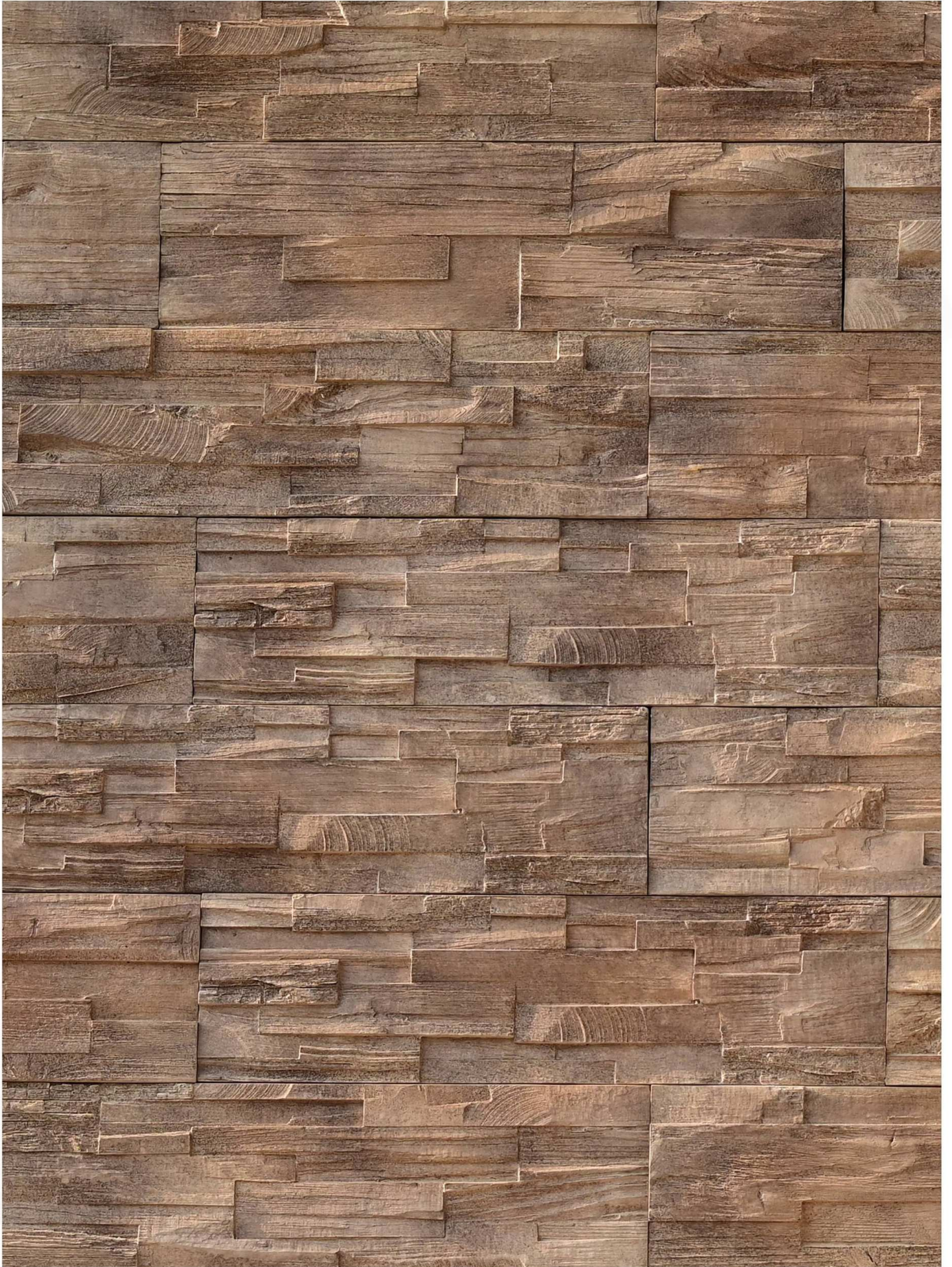

**BARN WOOD-VINTAGE**



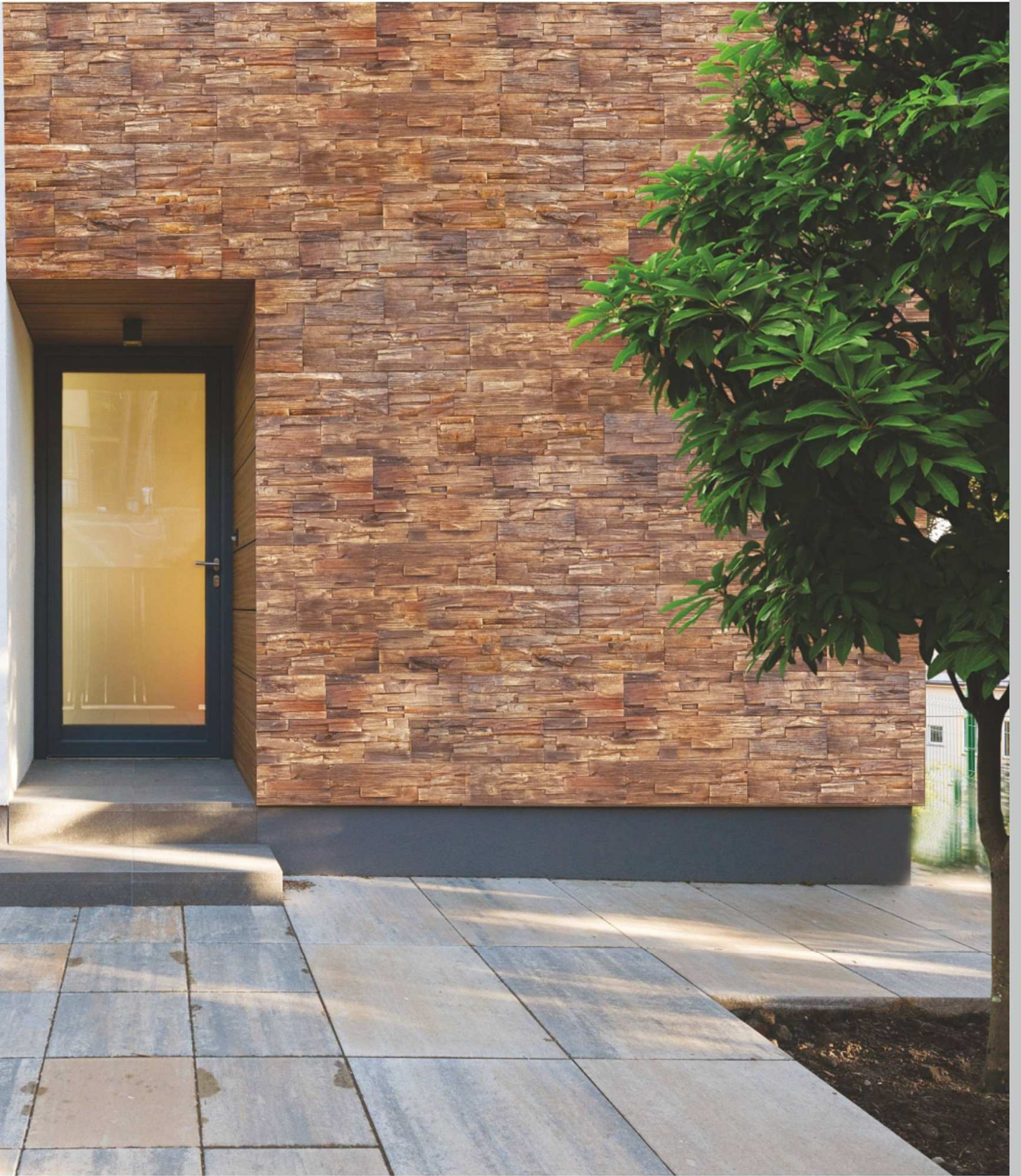

**BARN WOOD-VINTAGE**



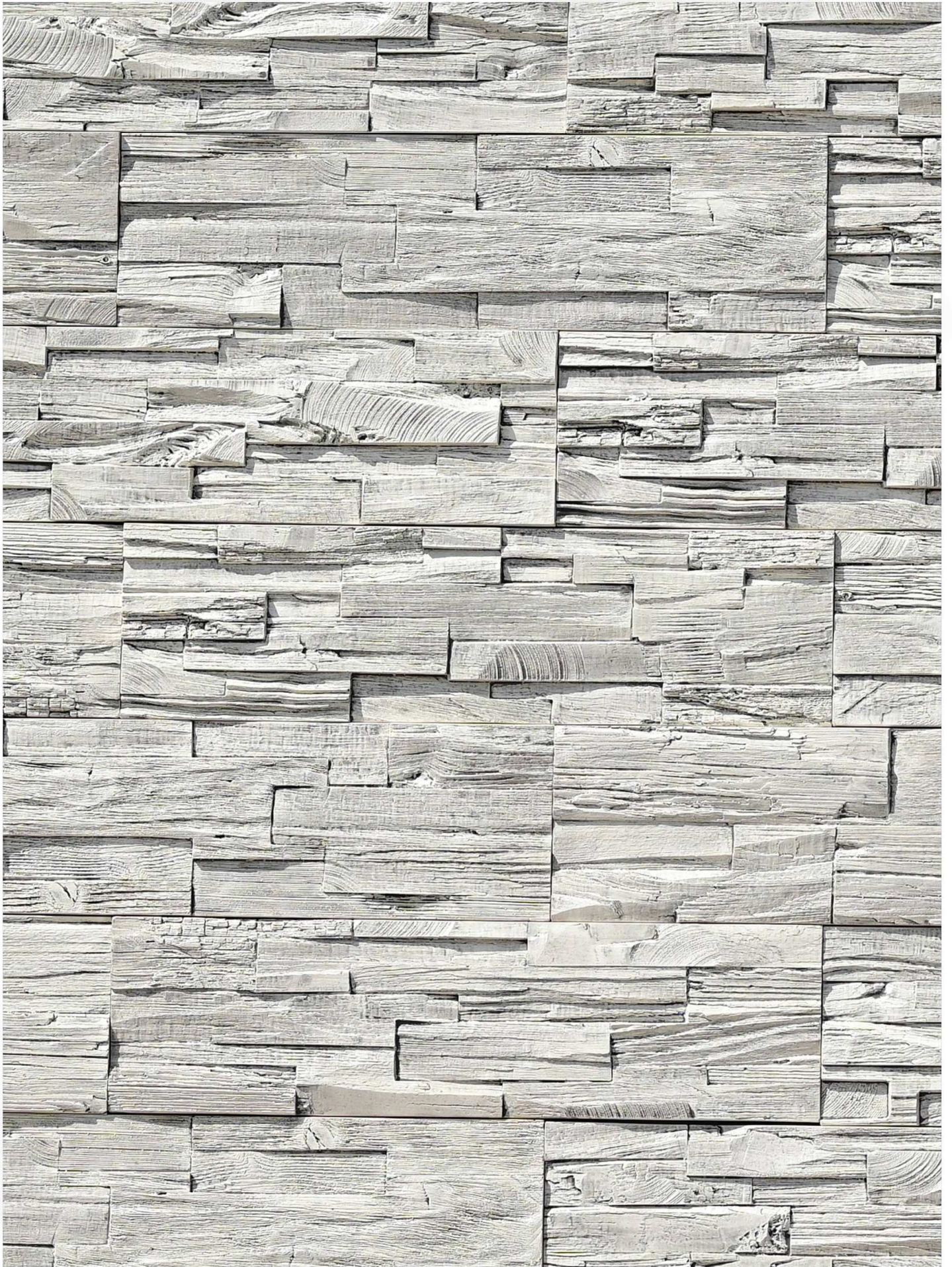

**BARN WOOD-ARCTIC WHITE**



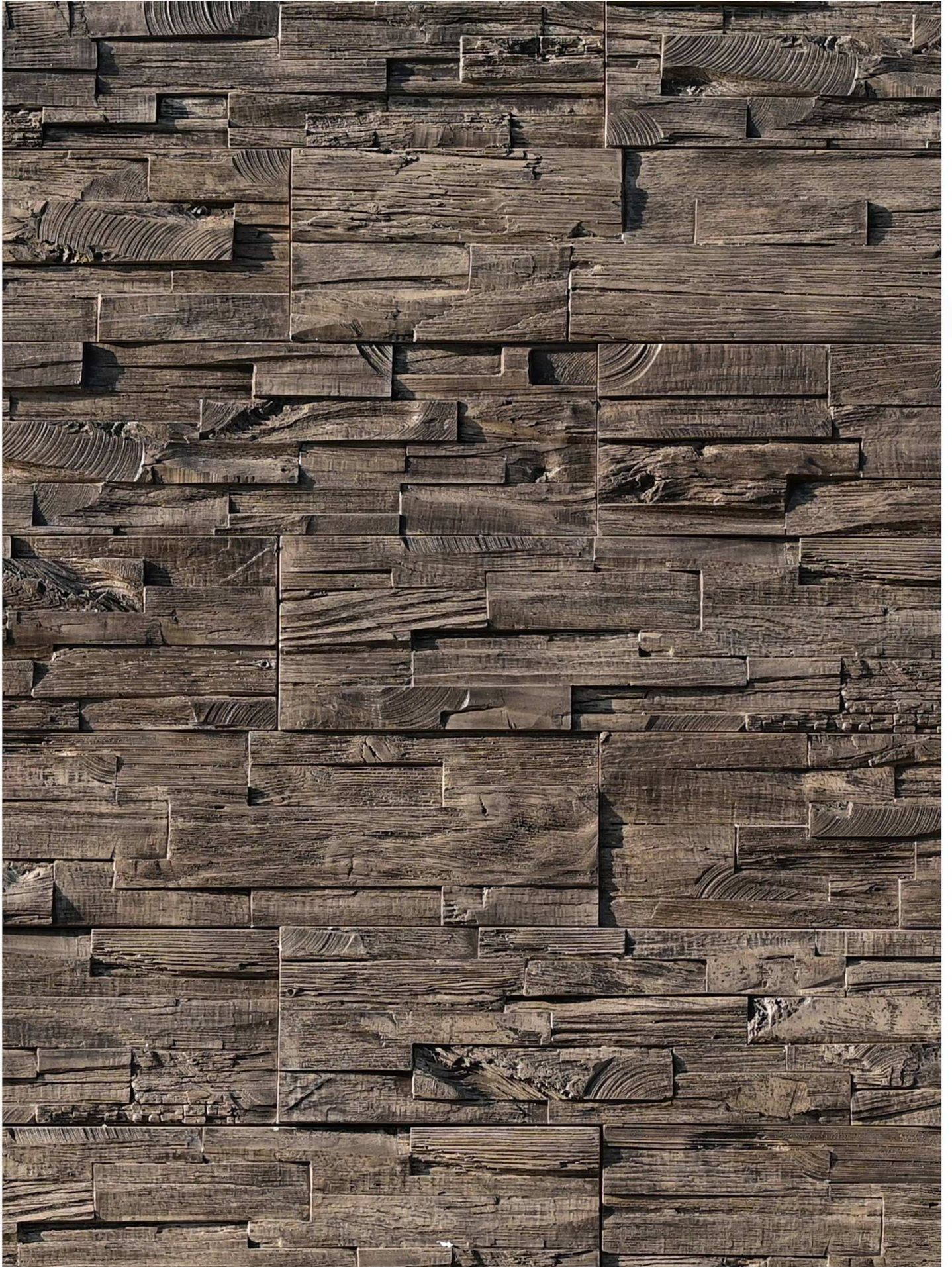



**BARN WOOD-COUNTRYSIDE**



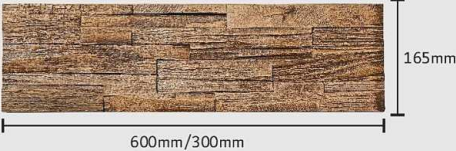
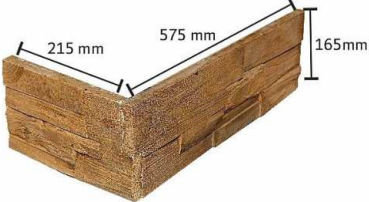

**BARN WOOD-COASTAL CREAM**

## SPECIFICATION

Flat Stone	Corner Stone	Thickness
 <p>600mm/300mm</p> <p>165mm</p> <p>Weight of stone: 3.5 kg per sq. ft (Approx.)</p>	 <p>215 mm</p> <p>575 mm</p> <p>165mm</p> <p>Area covered per running feet= 2.78 sq. ft.</p>	 <p>30mm</p>



Complete your installation with Matching Grouts & Adhesives.

STONEWIZ **ADHESIVE** IS HIGHLY FLEXIBLE, MULTIPURPOSE ADHESIVE FOR FIXING MANUFACTURED AND NATURAL STONE OF ALL TYPES AND SIZES.

**PRODUCT STRENGTHS**

- FOR INTERNAL AND EXTERNAL USE
- EXCELLENT BONDING STRENGTH
- WATER RESISTANT
- LONG OPEN TIME
- NO SHRINKAGE
- HIGH DEFORMATION



STONEWIZ **GROUT** IS A HIGHLY FLEXIBLE CEMENTITIOUS SANDED GROUTING MATERIAL WHICH AFTER FINISHING PROVIDES A COARSE TEXTURE THAT ENHANCES THE AUTHENTICITY OF APPLICATION OF OUR STONE WALL CLADDINGS. IT IS AVAILABLE IN A WIDE RANGE OF COLOURS WHICH COMPLIMENT OUR STONE AND ALSO MEET DIVERSE CUSTOMER PREFERENCES.

**PRODUCT STRENGTHS**

- FOR INTERNAL AND EXTERNAL USE
- COARSE TEXTURE
- WIDE RANGE OF COLOURS
- WATER RESISTANT
- NO SHRINKAGE

# GROUT

## COLOUR SHADES



ALMOND



ARCTIC WHITE



ASHLAR



COFFEE BROWN



DESERT SAND



HIGHLAND CREAM



IVORY



MISTY GREY



MUD BROWN



OLIVE GREEN



PEARL



POLAR WHITE



SILVER GREY



SOLANO BRWON



WARM GREY



## FREQUENTLY ASKED QUESTIONS



### 1. WHAT IS STONEWIZ STONE VENEER?

StoneWiz manufactures Architectural Stone Wall Veneer which harnesses the elegance and beauty of nature. Our proprietary blend of natural ingredients and the craftsmanship of our artisans has enabled us to create a product which captures the inherent beauty of natural stone without the negative environment impact of mining for natural stone. Our designs have been carefully selected from stones available from all across the world. Our artisans work diligently by hand to add life to the designs and manufacture a product which reflects the awe inspiring beauty of nature.

### 2. Why should you select StoneWiz Stone Veneer over natural stone?

Stone Wiz stones designs have been selected from most sought after designs available in various parts of the world and these designs are not available locally in natural stone.

- StoneWiz L-shaped corner stone pieces give your walls a most authentic and natural look.
- StoneWiz stones have been manufactured using light weight aggregates and much lighter in weight than natural stone.
- StoneWiz stone veneer does not cause the negative environmental impact caused by mining for natural stone.
- StoneWiz manufactured stone as compared to traditional natural stone is lightweight, easier and faster to install fungus resistant, eco friendly and require very little maintenance.

### 3. How are StoneWiz stones sold?

Flat pieces are sold by the square feet and corner pieces by the linear feet.

### 4. How are StoneWiz Stones packed for transport?

StoneWiz stones are available in cardboard packaging with proper cushioning to ensure safety during transportation.

### 5. What is the weight of Stonewiz stones?

Depending upon the design, StoneWiz stones usually weigh from 2.5 Kgs to 4 Kgs Per square feet.

### 6. Can StoneWiz stones products be cut?

Yes, StoneWiz stone products can easily be cut and trimmed with masonry circular saw.

### 7. Is any maintenance required for StoneWiz stones?

StoneWiz stone products are virtually maintenance free. All that is needed is occasional washing of the stone surfaces with plain water to remove any dust or debris that has settled down on the surface of the stone. However, never use any harsh detergents or chemicals on the surface of the stone or scratch the surface of the stone with any hard wired brush or any other object.





**HAND CRAFTED**

**8. What are the dimensions of the StoneWiz stones?**

The length, breadth and thickness of the stones varies between different textures manufactured. The average thickness of the stones ranges between 20mm to 50mm.

**9. What is the packing size of the stones?**

The packaging of the stones is done in cardboard boxes and is done in Square feet for stones and Linear feet for Stone Corners. Depending upon the texture selected the packaging size of the boxes varies from 6 sq ft to 13 sq ft per box.

**10. Where can I buy StoneWiz products?**

StoneWiz stone products can be purchased from StoneWiz Authorized resellers at numerous locations all over India. Please email at [contactus@stonewiz.in](mailto:contactus@stonewiz.in) for details regarding your nearest dealer location.

**11. Will StoneWiz stone products fade?**

Just as natural stone, StoneWiz stone products will experience normal weathering during the life of the installation, no different than any other cement based material. See Warranty card for details.

**12. What are the surfaces on which StoneWiz stones can be installed?**

StoneWiz products may be applied on most properly prepared, clean, untreated, structurally sound surfaces such as bricks, masonry, wood, plyboard or metal etc. Please refer to StoneWiz Installation Instructions for details on the installation process.

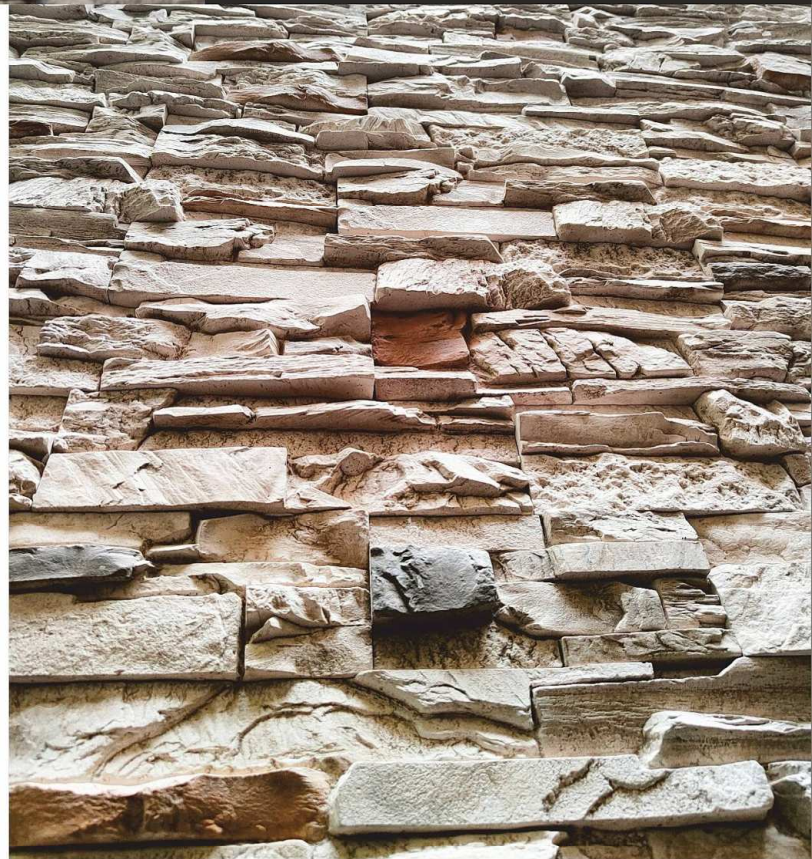

\*The colours in this catalog are as accurate as the photography & printing techniques may allow. Please look at the actual samples before finalizing your order.

\*The dimensions of stones may vary slightly from what they are mentioned in this catalog.

We would be happy to guide you to the nearest dealer to your location.

Email us at [contactus@stonewiz.in](mailto:contactus@stonewiz.in)





BRINGING YOU

*Closer to Nature*

**STONE**wiz®

✉ [contactus@stonewiz.in](mailto:contactus@stonewiz.in)

🌐 [www.stonewiz.in](http://www.stonewiz.in)



Scan QR to visit website



Indoor/Outdoor



Weather Proof



UV Resistant



Fire Resistant



Eco Friendly



Frost Resistant



Low Maintenance



Easy Installation



Detailed Natural  
Texture



Lightweight



Customizable